

# BEFORE DRIVING

- Fuel Recommendation ..... 3-1
- Keys ..... 3-2
- Door Locks ..... 3-3
- Windows ..... 3-5
- Mirrors ..... 3-6
- Front Seat Adjustment ..... 3-7
- Adjustable Head Restraints (if equipped) ..... 3-9
- Seat Belts ..... 3-9

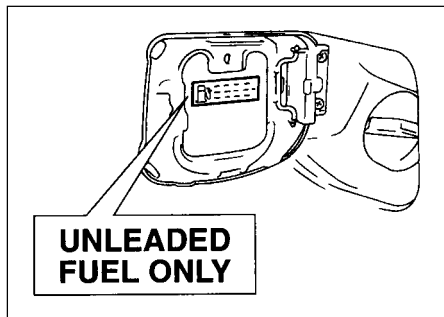

## FUEL RECOMMENDATION



60G-03-001E

You **must use unleaded petrol** with an octane number (RON) of 87 or higher. Your vehicle is fitted with a restrictor in the fuel filler pipe which will not allow the use of large nozzle used for dispensing leaded fuel at filling station. A label is also attached near the fuel filler pipe of your vehicle that states: "UNLEADED FUEL ONLY".

**▲ CAUTION**

**Use of leaded fuel in vehicle equipped with catalytic converter is prohibited, because lead deactivates the pollutant reducing components of catalytic converter and may result in permanent damage to catalytic converter.**

**Petrol/Ethanol Blends**

Blends of unleaded petrol and ethanol (grain alcohol), also known as gasohol, are commercially available in some areas. Blends of this type may be used in your vehicle if they are no more than 10% ethanol. Make sure this petrol-ethanol blend has octane ratings no lower than those recommended for petrol.

**Petrol/Methanol Blends**

Blends of unleaded petrol and methanol (wood alcohol) are also commercially available in some areas. **DO NOT USE** fuels containing more than 5% methanol under any circumstances. Fuel system damage or vehicle performance problems resulting from the use of such fuels are not the responsibility of MARUTI and may not be covered under Warranty.

Fuels containing 5% or less methanol may be suitable for use in your vehicle if they contain cosolvents and corrosion inhibitors.

**NOTE:**

*If you are not satisfied with the driveability or fuel economy of your vehicle when you are using a petrol/alcohol blend, you should switch back to unleaded petrol containing no alcohol.*

**▲ CAUTION**

**Be careful not to spill fuel containing alcohol while refuelling. Fuels containing alcohol can cause paint damage, which is not covered under Warranty.**

**▲ CAUTION**

**The fuel tank has an air space to allow for fuel expansion in hot weather. If you continue to add fuel after the filler nozzle has automatically shut off or an initial blowback occurs, the air chamber will become full. Exposure to heat when fully fuelled in this manner will result in leakage due to fuel expansion. To prevent such fuel leakage, stop filling after the filler nozzle has automatically shut off, or when using an alternative non automatic system, initial vent blowback occurs.**

## KEYS

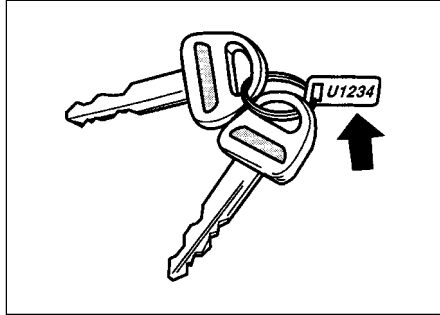

70F-01-003

Your vehicle comes with a pair of identical keys. Keep the spare key in a safe place. One key can open all of the locks on the vehicle.

The key identification number is stamped on a metal tag provided with the keys. Keep the tag in a safe place. If you lose your keys, you will need this number to have new keys made. Write the number down and keep it in a safe accessible place away from the vehicle.

**⚠ WARNING**

- Do not use locally made key.
- Should you require a duplicate key, place your order with a MARUTI dealer only.

*Note:*

*Keep the spare key very carefully. When it is lost, consult your dealer by quoting key number.*

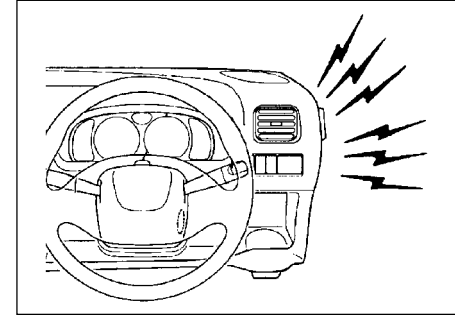

79F-03-001

**Ignition Key Reminder (if equipped)**

A buzzer sounds intermittently to remind you to remove the ignition key if it is in the ignition switch when the driver's door is opened.

## DOOR LOCKS

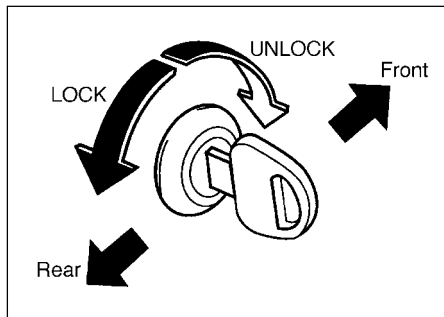

79F-03-002E

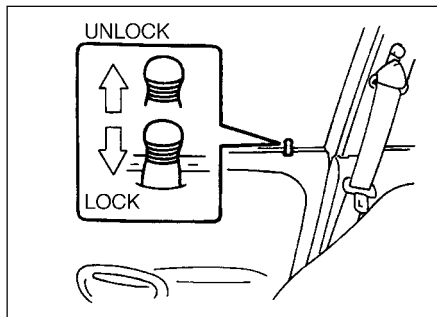

60G-03-004E

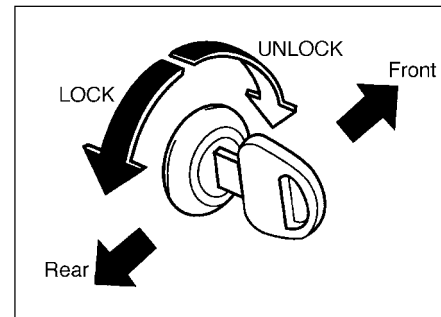

79F-03-002E

**Side Door Locks**

To lock a front door from outside the vehicle:

- Insert the key fully and turn the top of the key toward the rear of the vehicle, or
- Push in the lock knob down and hold the door handle up as you close the door.

To unlock a front door from outside the vehicle, insert the key fully and turn the top of the key toward the front of the vehicle.

To lock a rear door from outside the vehicle, push in the lock knob down and close the door.

To lock a door from inside the vehicle, push the lock knob down. Pull the lock knob up to unlock the door.

**⚠ WARNING**

**Always lock all doors when driving. Locking the door prevents occupants from being thrown from the vehicle in the event of an accident. It also helps prevent unintentional opening of the doors.**

**Central door locking system (if equipped)**

You can lock and unlock all the side doors and the rearend door simultaneously by using the key in the driver's door lock.

You can also lock or unlock all the side doors and the rearend door by pushing down or pulling up the driver's door lock knob.

**NOTE:**

- Moving the lock knob on passenger's door locks or unlocks the passenger's door only.
- Be sure to hold the door handle up when you close a locked front door, or the door will not remain locked.

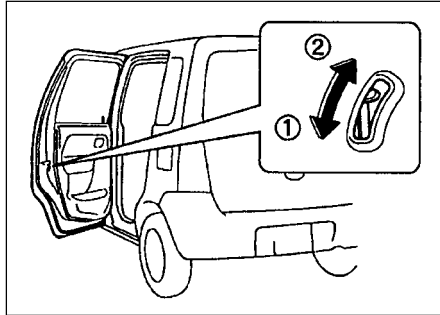

79F-03-003

### Child-Proof Locks (if equipped)

As illustrated, a child-proof lock is provided for both rear doors. When the lock lever is down, position ①, the child proof lock is activated, and when up, in position ② the child-proof lock is deactivated, when the child-proof lock is activated, the rear door cannot be opened from the inside even if the inside door lock is unlocked but can be opened from the outside.

#### **⚠ WARNING**

Be sure to place the child-proof lock in the locked position whenever children are seated in the rear.

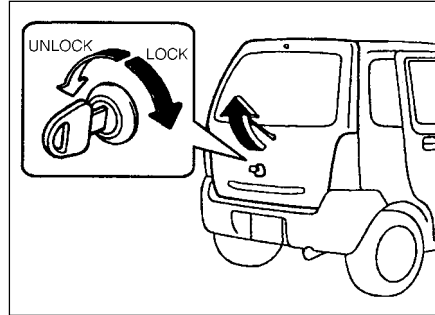

79F-03-004E

### Rearend Door Lock

To unlock the door, insert the key into the lock knob and turn it anticlockwise and to lock turn it clockwise. Rearend door can be opened by pushing in the lock knob and lifting the grip.

#### **⚠ WARNING**

Always make sure that the rearend door is closed and latched securely. Closing the door completely helps to prevent exhaust gases from entering the vehicle. Completely closing the rearend door also helps prevent occupants from being thrown from the vehicle in the event of an accident.

#### **⚠ CAUTION**

Do not use the key to lift up the lid, or the key may break off in the lock.

## WINDOWS

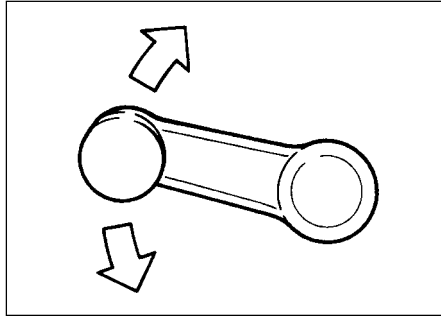

60G-03-008

Raise or lower the door windows by turning the handle located on the door panel.

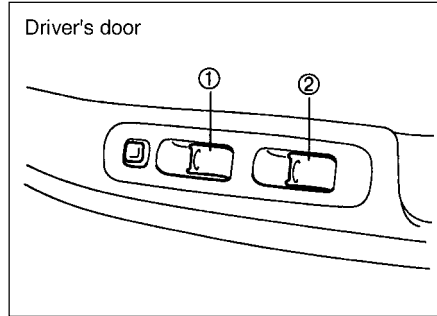

79F-03-005E

**Electric window controls (if equipped)**  
The driver's door has switches ① & ② to operate the driver's window and front passenger's window respectively.

The passenger's door only has a switch ③ to operate the passenger's window. The electric windows can only be operated when the ignition switch is in the "ON" position.

To open a window with the driver's door switches, push the top part of the switch and to close the window lift up the top part of the switch.

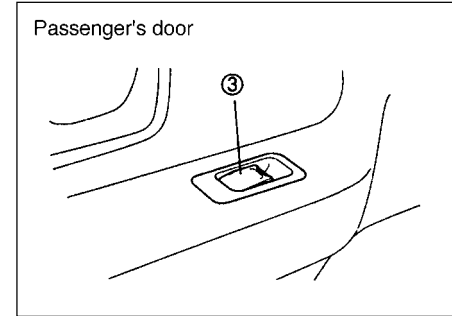

79F-03-006E

The driver's window has an "auto-down" feature for added convenience (at toll booths or drive-through restaurants, for example). This means you can open the window without holding the window switch in the "Down" position. Press the driver's window switch completely down and release it. To stop the window before it reaches the bottom, lift up the switch briefly.

To open or to close a window with the passenger's door switch, push the top part of the switch or lift up the top part of the switch.

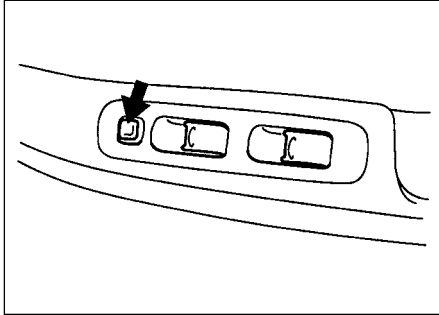

79F-03-007

The driver's door also has a lock switch for the passenger's window. When you push in the lock switch, the passenger's window can not be raised or lowered by operating either of the switches ② or ③. To restore normal operation, push the switch again.

### ⚠ WARNING

**You should always push in the lock switch when there are children in the vehicle. Children can be seriously injured if they get part of their body caught by the window during operation.**

### ⚠ CAUTION

**Since the electric windows consumes a large amount of electricity, the same should not be used excessively with engine in "OFF" condition.**

## MIRRORS

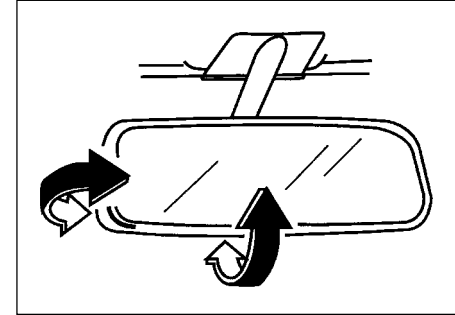

70F-01-013

### Inside Rearview Mirror

To adjust the inside rearview mirror, move the mirror up, down, or sideways to obtain the best view.

## FRONT SEAT ADJUSTMENT

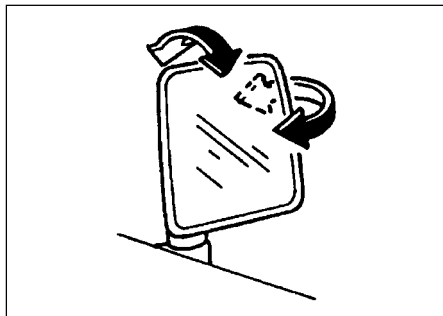

79F-03-008

**Outside Rearview Mirrors**

Adjust the outside rearview mirrors so you can just see the side of your vehicle in the mirrors. Either the convex mirror or the flat mirror is equipped.

**⚠ WARNING**

Be careful when judging the size or distance of a vehicle or other object seen in the side convex mirror (if equipped). Be aware that objects look smaller and appear farther away than when seen in a flat mirror.

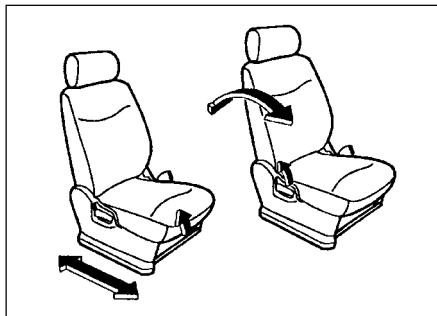

79F-03-009

**⚠ WARNING**

Never attempt to adjust the driver's seat or seatback while driving. The seat or seatback could move unexpectedly, causing loss of control. Make sure that the driver's seat and seatback are properly adjusted before you start driving.

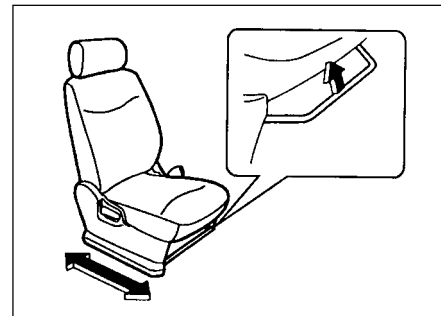

79F-03-010

**Adjusting Seat Position**

The adjustment lever for each front seat is located under the front of the seat. To adjust the seat position, pull up on the adjustment lever and slide the seat forward or rearward. After adjustment, try to move the seat forward and rearward to ensure that it is securely latched.

**⚠ WARNING**

To avoid excessive seat belt slack, which reduces the effectiveness of the seat belts as a safety device, make sure that the seats are adjusted before the seat belts are fastened.

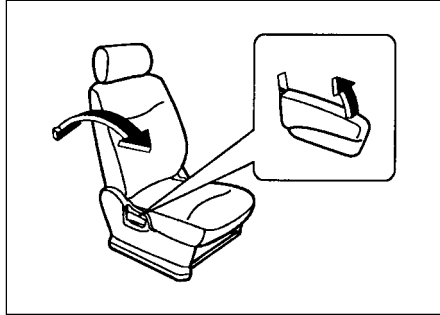

79F-03-011

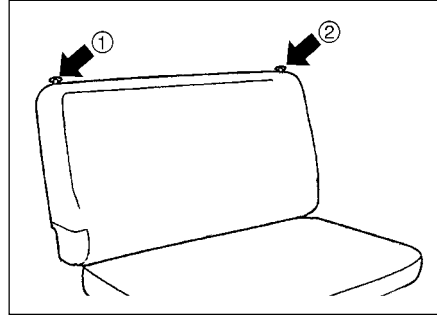

79F-03-012

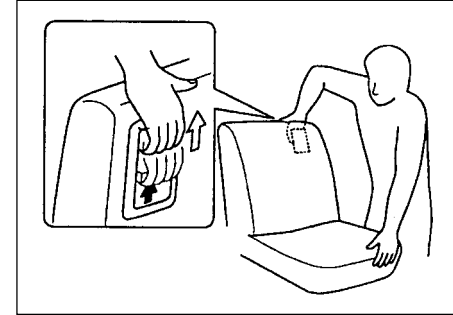

79F-03-013

### Adjusting Seatbacks

#### **▲ WARNING**

**Seatbacks should always be in an upright position when driving, or seat belt effectiveness may be reduced. Seat belts are designed to offer maximum protection when seatbacks are in the fully upright position.**

### Front Seats

The seatbacks can be adjusted to different angles. To adjust the seatback angle, pull up the lever on the outboard side of the seat, move the seatback to the desired position, and release the lever to lock the seatback in place.

### Rear Seats

The rear seatback(s) can be adjusted to different angles.

- To adjust the seatback angle of rear seats;
- Pull up the two lock knobs (① & ②) simultaneously for nonsplit type seatback. or  
Pull up the lever on the back of a split folding seat (if equipped)
  - Move the seatback to one of the lock positions.
  - Release the knobs/lever and move the seatback to lock the seatback in position. After adjustment, try moving the seatback to make sure it is securely locked.

### ADJUSTABLE HEAD RESTRAINTS (if equipped)

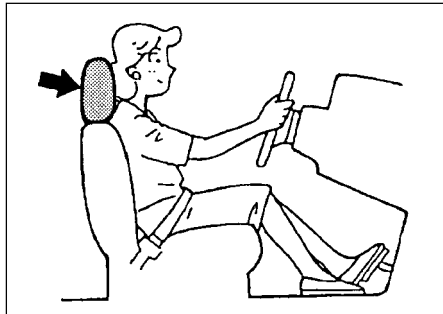

70F-01-019

#### ⚠ WARNING

- Never drive the vehicle with the head restraints removed.
- Do not attempt to adjust the head restraint while driving.

Head restraints are designed to help reduce the risk of neck injuries in the case of an accident. Adjust the head restraint to the position which places the top of the head restraint closest to the top of your ears.

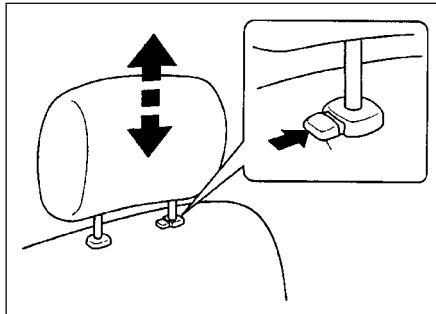

79F-03-014

To raise the head restraint, pull upward on the restraint until it clicks. To lower the restraint, push down on the restraint while holding in the lock lever. If a head restraint must be removed (for cleaning, replacement, etc.), push in the lock lever and pull the head restraint all the way out.

### SEAT BELTS

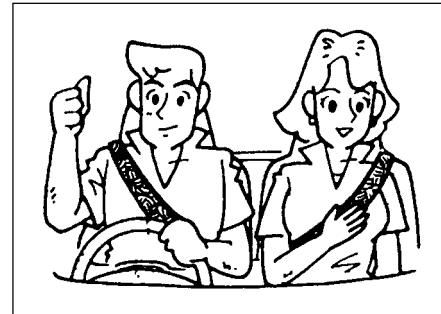

70F-06-001

#### ⚠ WARNING

Seat belts are good help to protect occupants from injury or death in the event of accidents. We urge you to wear seat belts at all times if the belts are equipped. If seat belts are not equipped at the rear seating positions, we recommend you to install optional or after market high quality seat belts to increase occupant's safety.

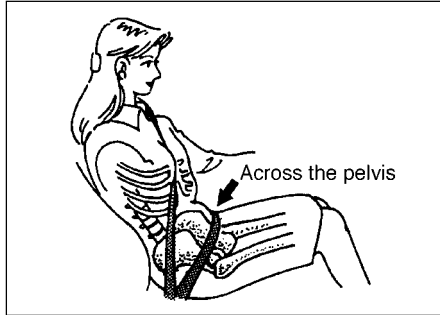

79F-03-015E

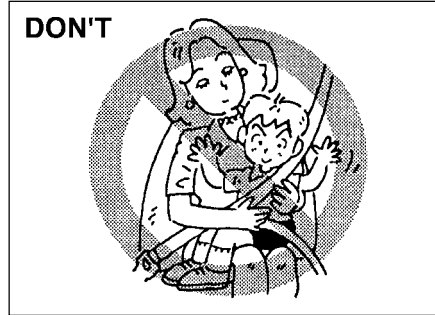

79F-03-016E

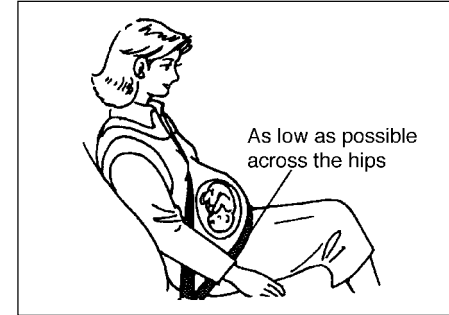

79F-03-017E

### ▲ WARNING

- Never allow persons to ride in the cargo area of a vehicle. In the event of an accident, there is a much greater risk of injury for persons who are not riding in a seat with their seat belt securely fastened.
- Seat belts should always be adjusted so the lap portion of the belt is worn low across the pelvis, not across the waist. Shoulder straps should be worn on the outside shoulder only, and never under the arm. Seat belts should never be worn with the straps twisted and should be adjusted as



### ▲ WARNING



- tightly as is comfortable to provide the protection for which they have been designed. A slack belt will provide less protection than one which is snug.
- Make sure that each seat belt buckle is inserted into the proper buckle catch.
  - Do not wear your seat belt over hard or breakable objects in your pockets or on your clothing. If an accident occurs, objects such as glasses, pens, etc. under the seat belt can cause injury.



### ▲ WARNING



- Never use the same seat belt on more than one occupant and never attach a seat belt over an infant or child being held on an occupant's lap. Such seat belt use could cause serious injury in the event of an accident.
- Pregnant women should use seat belts, although specific recommendations about restraint use should be made by the woman's medical advisor. Remember that the lap portion of the belt should be worn as low as possible across the hips, as shown in the diagram.



**⚠ WARNING**

- Periodically inspect seat belt assemblies for excessive wear and damage. Seat belts should be replaced if webbing becomes frayed, contaminated, or damaged in any way. It is essential to replace the entire seat belt assembly after it has been stressed in an impact, even if damage to the assembly is not obvious.
- Infants and small children should never be transported unless they are properly restrained. Restraint systems for infants and small children can be purchased locally and should be used. Make sure that the system you purchase meets applicable safety standards. Read and follow all the directions provided by the manufacturer.
- Avoid contamination of seat belt webbing by polishes, oils, chemicals, and particularly battery acid. Cleaning may safely be carried out using mild soap and water.
- For children, if the shoulder belt irritates the neck or face, move the child closer to the center of the vehicle.

**⚠ WARNING**

Be sure to inspect all seat belt assemblies after any collision. Any seat belt assembly which was in use during a collision (other than a very minor one) should be replaced, even if damage to the assembly is not obvious. Any seat belt assembly which was not in use during a collision should be replaced if it does not function properly or is damaged in any way.



79F-03-018

To fasten the seat belt, sit up straight and well back in the seat, pull the buckle tongue attached to the seat belt across your body and slide it into the buckle catch on the opposite side until you hear a “click”.

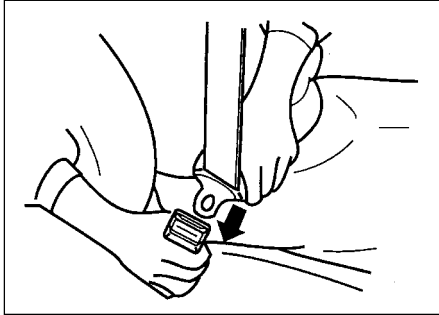

70F-01-021

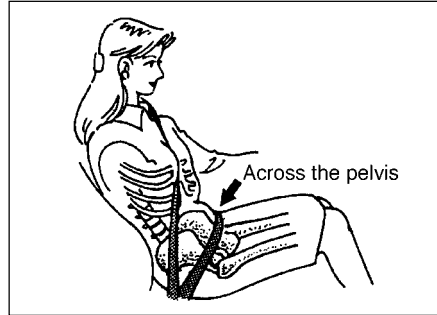

79F-03-015E

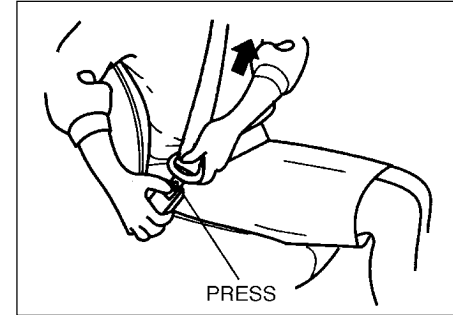

70F-01-023E

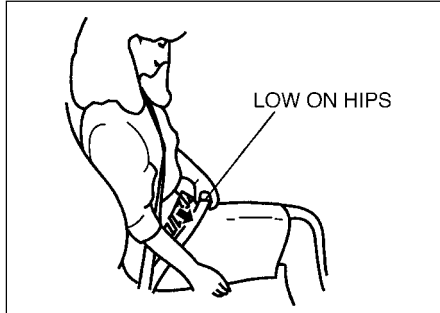

70F-01-022E

To reduce the risk of sliding under the belt during a collision, position the lap portion of the belt across your lap as low on your hips as possible and adjust the belt to a snug fit using the proper method for each type of the belt as described below. Make sure that the belt is not twisted.

To unfasten the belt, press the release button on the buckle catch.

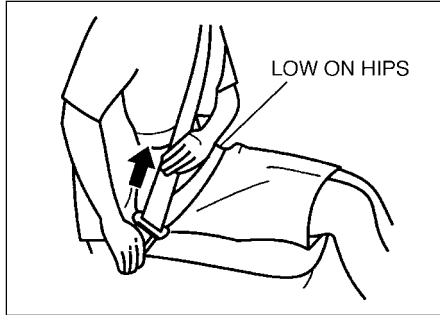

70F-01-024E

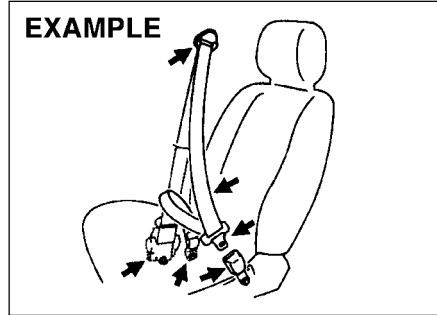

79F-03-019E

### To Adjust the Belt

- Pull the shoulder portion of the belt upwards through the tongue plate.

The length of the diagonal shoulder strap adjusts itself to allow freedom of movement. The seat belt has an emergency locking retractor (ELR), which is designed to lock the seat belt only during a sudden stop or impact.

### **▲ WARNING**

**No modifications or additions of any sort should be made to the seat belt or its operating mechanism.**

### Seat Belt Inspection

Periodically inspect the seat belts to make sure they work properly and are not damaged. Check the webbing, buckles, latch plates, retractors, anchorages and guide loops. Replace any seat belts which do not work properly or are damaged.

## STEERING COLUMN CONTROLS

Ignition Switch .....	4-1
Lighting/Turn Signal Control Lever .....	4-2
Hazard Warning Switch .....	4-4
Windscreen Wiper and Washer Lever .....	4-4
Horn .....	4-5
Electrical Power Steering (If equipped) .....	4-5

IGNITION SWITCH

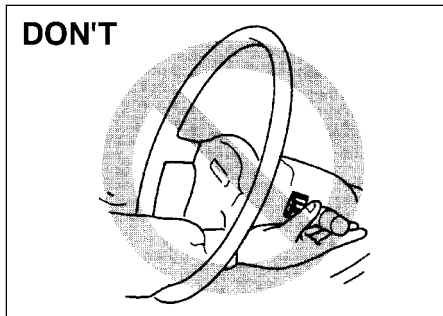

**⚠ WARNING**  
 To avoid possible injury, do not operate controls by reaching through the steering wheel.

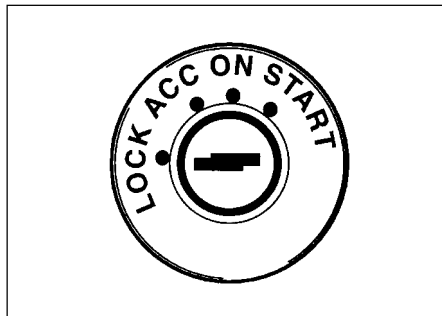

The ignition switch has the following four positions:

**⚠ WARNING**

- Do not use any locally made key.
- Should you require duplicate key, place your order with MARUTI dealer only.

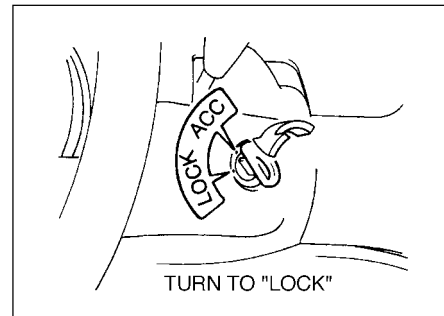

**LOCK**  
 This is the normal parking position. It is the only position in which the key can be removed.

The "LOCK" position locks the ignition, and prevents normal use of the steering wheel after the key is removed.

To release the steering lock, fully insert the key and turn it clockwise to one of the other positions. If you have trouble turning the key to unlock the steering, try turning the steering wheel slightly to the right or left while turning the key.

**ACC**

Accessories such as the radio can operate, but the engine is off.

**ON**

This is the normal operating position. All electrical systems are on.

**START**

This is the position for starting the engine using the starter motor. The key should be released from this position as soon as the engine starts.

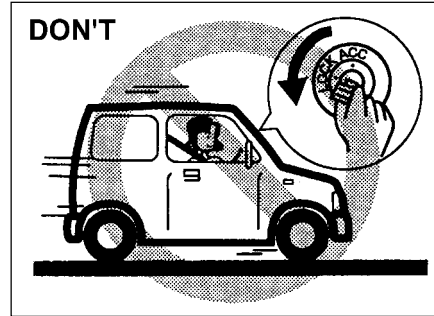

79F-04-002E

**▲ WARNING**

- Never remove the ignition key while the vehicle is moving. The steering wheel will lock and you will not be able to steer the vehicle.
- Do not leave children alone in a parked vehicle. Unattended children could cause accidental movement of the vehicle, which could result in severe personal injury.
- Always remove the key when parked to prevent unintentional operation of the vehicle and to improve security.

**▲ CAUTION**

- Do not use the starter motor for more than 15 seconds at a time. If the engine does not start; wait 15 seconds before trying again. If the engine does not start after several attempts, check the fuel and ignition systems or consult your MARUTI dealer.
- Do not leave the ignition switch in the "ON" position if the engine is not running as the battery will discharge.

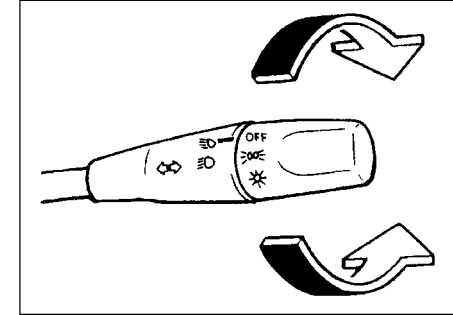
**LIGHTING/TURN SIGNAL CONTROL LEVER**

60G-04-003

This control lever is located on the outboard side of the steering column. Operate the lever as described below.

**Lighting Operation**

To turn the lights on or off, twist the knob on the end of the lever. There are three positions: in the "OFF" position all lights are off; in the middle position the front parking lights, tail-lights, registration plate light, and instrument lights are on, but the headlights are off; in the third position the headlights come on in addition to the other lights.

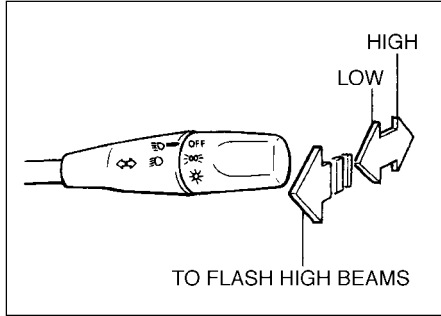

60G-04-004E

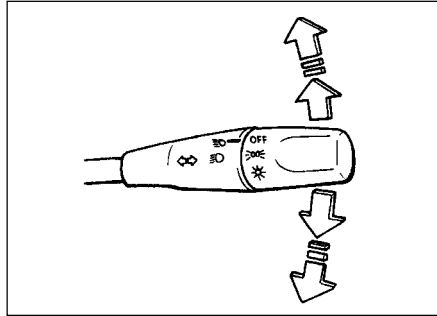

60G-04-005

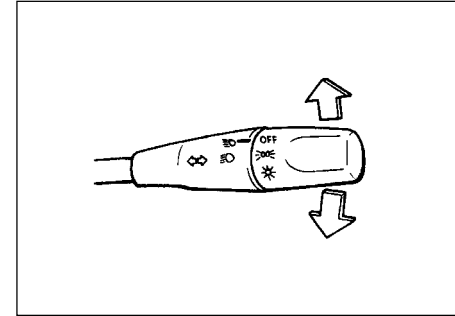

60G-04-006

With the headlights on, push the lever forward to switch to the high beams (main beams) or pull the lever toward you to switch to the low beams. When the high beams (main beams) are on, a light on the instrument panel will come on. To flash the high beams (main beams) pull the lever slightly towards you and release it.

**Lights "On" Reminder (if Equipped)**

A buzzer/chime sounds to remind you to turn off the lights if they are left on when the ignition key is removed and the driver's door is opened.

**Turn Signal Operation**

With the ignition switch in the "ON" position, move the lever up or down to activate the left or right turn signals.

**Normal Turn Signal**

Move the lever clockwise until it clicks to signal a right turn or anticlockwise to signal a left turn. When the turn is completed, the signal will cancel and the lever will return to its normal position.

**Lane Change Signal**

Some times, such as when changing lanes, the steering wheel is not turned far enough to cancel the turn signal. For convenience, you can flash the turn signal by moving the lever part way and holding it there. The lever will return to its normal position when you release it.

### HAZARD WARNING SWITCH

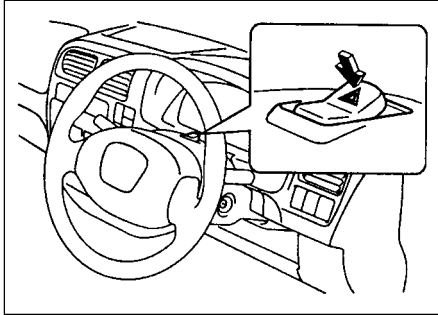

79F-04-003

Push in the marked part of the hazard warning switch to activate the hazard warning lights. All four turn signal lights and both turn signal indicators will flash simultaneously. To turn off the lights, push the other side of the switch.

Use the hazard warning lights to warn other traffic during emergency parking or when your vehicle could otherwise become a traffic hazard.

### WINDSCREEN WIPER AND WASHER LEVER

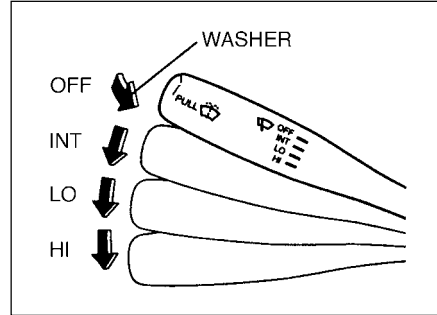

79F-04-004E

#### Windscreen Wipers

To turn the windscreen wipers on, move the lever down to one of the three operating positions. In the "INT" position (if equipped), the wipers operate intermittently. The "INT" position is very convenient for driving in mist or light rain. In the "LO" position, the wipers operate at a steady low speed. In the "HI" position, the wipers operate at a steady high speed. To turn off the wipers, move the lever back to the "OFF" position.

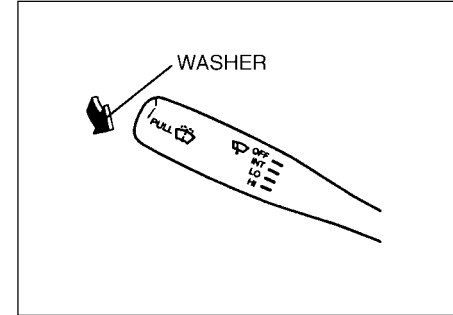

79F-04-005E

#### Windscreen Washer

To spray windscreen washer fluid, pull the lever toward you. The windscreen wipers will automatically turn on at low speed if they are not already on and the "INT" position is equipped.

#### **▲ WARNING**

- To prevent windscreen icing in cold weather, turn on the defroster to heat the windscreen before and during windscreen washer use.
- Do not use radiator antifreeze in the windscreen washer reservoir. It can severely impair visibility when sprayed on the windscreen, and can also damage your vehicle's paint.

**▲ CAUTION**

To help prevent damage to the windshield wiper and washer system components, you should take the following precautions:

- Do not continue to hold in the lever when there is no windshield washer fluid being sprayed or the washer motor can be damaged.
- Do not attempt to remove dirt from a dry windshield with the wipers or you can damage the windshield and the wiper blades. Always wet the windshield with washer fluid before operating the wipers.
- Clear ice or packed snow from the wiper blades before using the wipers.
- Check the washer fluid level regularly. Check it often when the weather is bad.
- Only fill the washer fluid reservoir 3/4 full during cold weather to allow room for expansion if the temperature falls low enough to freeze the solution.

**HORN**

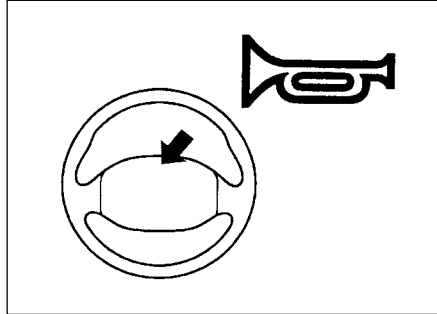

79F-04-006

Press the horn button of the steering wheel to sound the horn. The horn will sound with the ignition switch in any position.

**ELECTRIC POWER STEERING (if equipped)**

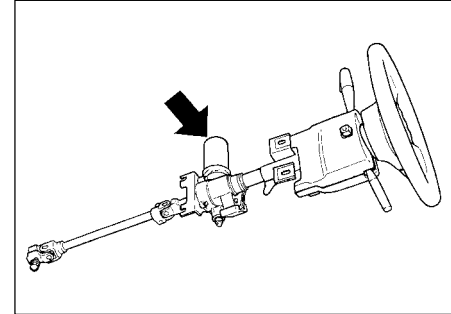

72F-09-013

Depending on specifications, your vehicle is equipped with electric power steering system to reduce the steering effort while driving.

## INSTRUMENT PANEL

Instrument Panel .....	5-1
Instrument Cluster .....	5-2
Warning and Indicator Lights .....	5-3
Speedometer/Odometer/Tripmeter .....	5-5
Tachometer (if equipped) .....	5-6
Fuel Gauge .....	5-7
Temperature Gauge .....	5-7
Rear Window Wiper/Washer Switch (if equipped) .....	5-7
Ashtray .....	5-8
Glove Box .....	5-8
Heating System (if equipped) .....	5-9
System Operating Instructions .....	5-10
Air Conditioning System (if equipped) .....	5-13
System Operating Instructions .....	5-13

INSTRUMENT PANEL

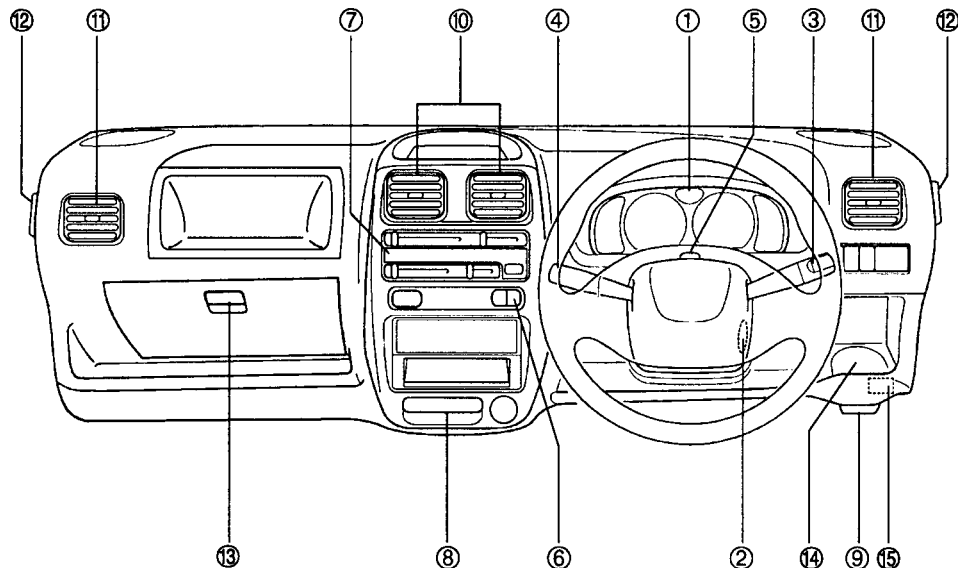

1. Instrument cluster
2. Ignition switch
3. Lighting switch/Turn signal and dimmer switch
4. Windscreen wiper and washer switch
5. Hazard warning switch
6. Other switches (if equipped)
7. Heater control panel
8. Ashtray
9. Bonnet release
10. Center ventilator
11. Side ventilator
12. Side defroster
13. Glove box
14. Cup holder
15. Fuse box

79F-05-001

## INSTRUMENT CLUSTER

## TYPE-1

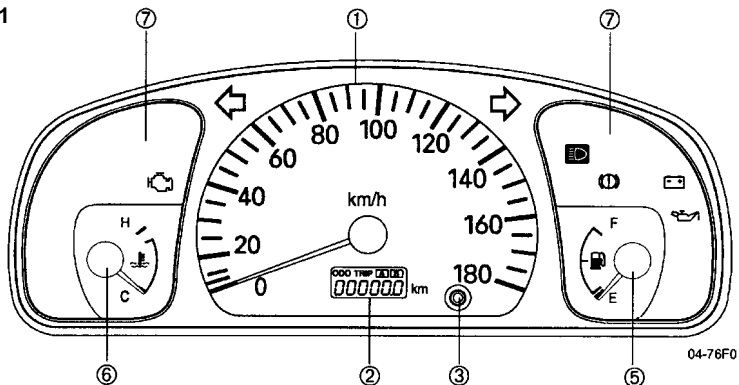

79F-05-002

## TYPE-2

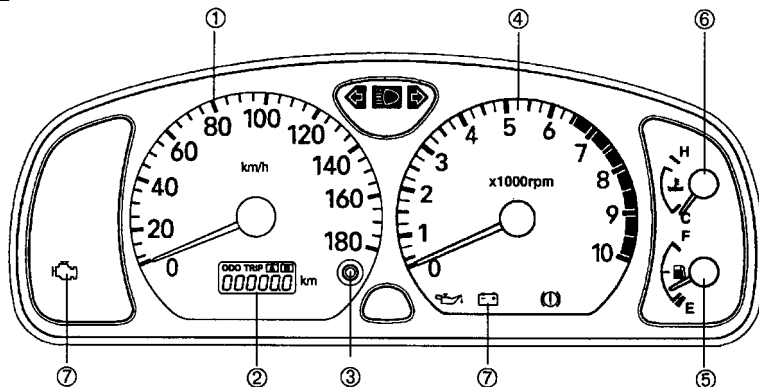

79F-05-003

- ① Speedometer
- ② Odometer/Trip meter
- ③ Odometer/Trip meter selector knob
- ④ Tachometer (if equipped)
- ⑤ Fuel gauge
- ⑥ Temperature gauge
- ⑦ Warning and indicator lights

## WARNING AND INDICATOR LIGHTS



70F-07-070

**Brake fluid level warning/Parking Brake Indicator light**

This light operates under two conditions with the ignition switch turned to the "ON" position, 1) When the parking brake is engaged, 2) when the fluid in the brake fluid reservoir falls below the specified level. The light should go out after starting the engine and fully releasing the parking brake, if the fluid in the brake fluid reservoir is adequate.

If the light does not go off or comes on whilst you are driving, it may mean that there is something wrong with the vehicle's braking system. If this happens, you should:

- 1) Pull off the road and stop carefully.

**▲ WARNING**

**Remember that stopping distance may be longer, you may have to push harder on the pedal, and the pedal may go down farther than normal.**

- 2) Test the brakes by carefully starting and stopping at the side of the road.
  - 3) If you determine that it is safe, drive carefully at low speed to the nearest dealer for repairs.
- or
- 4) Have the vehicle towed to the nearest dealer for repairs.

**▲ WARNING**

**If any of the following conditions occur, you should immediately ask your MARUTI dealer to inspect the brake system.**

- **If the brake fluid level warning light does not go out after the engine has been started and the parking brake has been fully released.**
- **If the brake fluid level warning light does not come on when the ignition switch is turned to the "ON" position with the parking brake applied.**
- **If the brake fluid level warning light comes on at any time during vehicle operation.**

**NOTE:**

*Because the disc brake system is self adjusting, the fluid level will drop as the brake pads become worn.*

*Replenishing the brake fluid reservoir is considered normal periodic maintenance.*

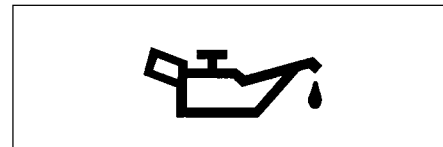

70F-03-039

**Oil Pressure Light**

This light comes on when the ignition switch is turned on, and goes out when the engine is started. The light will come on and remain on if there is insufficient oil pressure. If the light comes on when driving, pull off the road as soon as you can and stop the engine. Check the oil level and add oil if necessary (see pages 9-7 and 9-8). If there is enough oil, the lubrication system should be inspected by your MARUTI dealer before you drive the vehicle again.

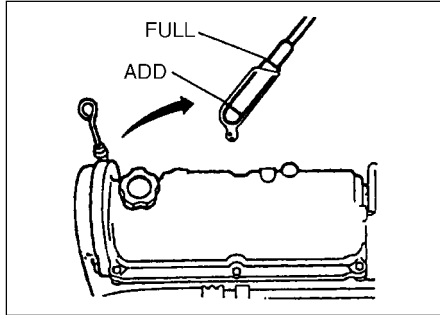

79F-09-002

### ▲ CAUTION

- If you operate the engine with this light on, severe engine damage can result.
- Do not rely on the Oil Pressure Light to indicate the need to add oil. Be sure to periodically check the engine oil level (see pages 9-8 and 9-9).

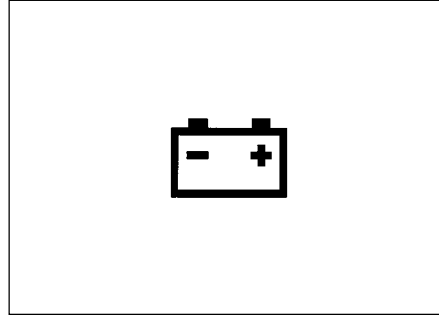

70F-03-009

### Charging Light

This light comes on when the ignition switch is turned on, and goes out when the engine is started. The light will come on and remain on if there is something wrong with the battery charging system. If the light comes on when the engine is running, the charging system should be inspected immediately by your MARUTI dealer.

### ▲ CAUTION

Do not continue driving long with the charging light ON as this will drain the battery 'dead'.

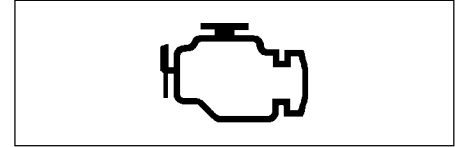

72F-05-027

### “Malfunction Indicator” Light

Your vehicle has a computer-controlled emission control system. A “Malfunction Indicator” light is provided on the instrument panel to indicate when it is necessary to have the emission control system serviced. The “Malfunction Indicator” light comes on when the ignition switch is turned to “ON” and goes out when the engine is started.

If the “Malfunction Indicator” light comes on when the engine is running, there is a problem with the emission control system. Take the vehicle to your MARUTI dealer to have the problem corrected.

### ▲ CAUTION

Continuing to drive the vehicle when the “Malfunction Indicator” light is on can cause permanent damage to the vehicle’s emission control system, and can affect fuel economy and driveability.

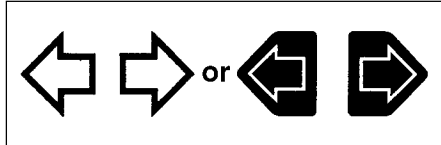

79F-05-004E

**Turn Signal Indicators**

When you turn on the left or right turn signals, the corresponding green arrow on the instrument panel will flash along with the respective turn signal lights. When you turn on the hazard warning switch, both arrows will flash along with all of the turn signal lights.

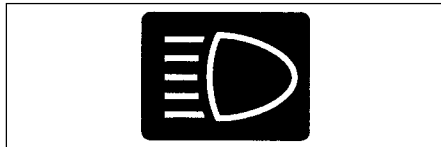

79F-05-005

**Main Beam (High Beam) Indicator Light**

This indicator comes on when headlight main beams (high beams) are turned on.

**SPEEDOMETER/ODOMETER/TRIPMETER**

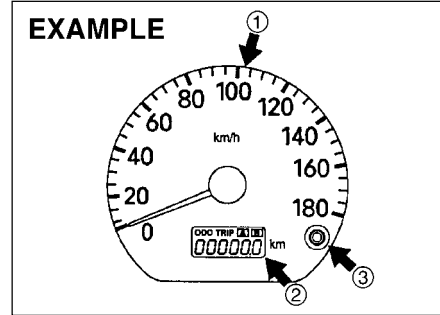

79F-05-006E

- ① Speedometer
- ② Odometer/Trip meter
- ③ Odometer/Trip meter selector knob

The speedometer indicates vehicle speed in km/h. The odometer records the total distance the vehicle has been driven. The tripmeter can be used to measure the distance travelled on short trips or between fuel stops.

<p><b>⚠ CAUTION</b></p> <p><b>Keep track of your odometer reading and check the maintenance schedule regularly for required services. Increased wear or damage to certain parts can result from failure to perform required services at the proper mileage intervals and your warranty rights may be affected.</b></p>
--

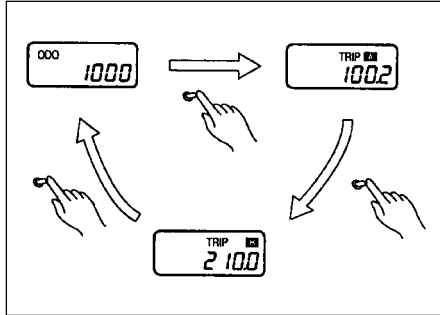

79F-05-007

When the ignition switch is turned to "ON" the display shows the odometer or trip meter.

The display shows three types of indication; odometer, trip meter A and trip meter B. Push the selector knob quickly to switch the indication among the three.

You can use the two trip meters (A and B) independently.

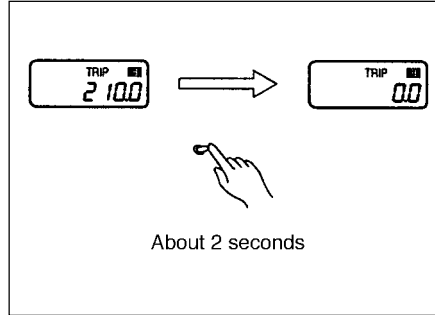

79F-05-008E

Push the selector knob for a little while (about 2 seconds) to reset the trip meter to zero.

### TACHOMETER (if equipped)

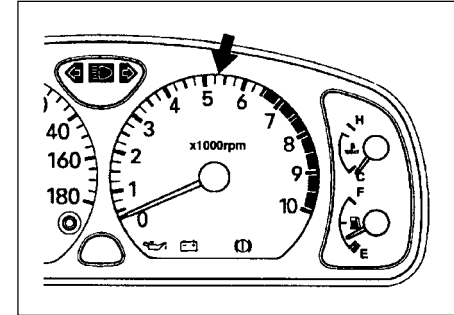

79F-05-009

The tachometer indicates engine speed in revolutions per minute.

#### **▲ CAUTION**

**Never drive with the engine speed indicator in the red zone or severe engine damage can result.**

**FUEL GAUGE**

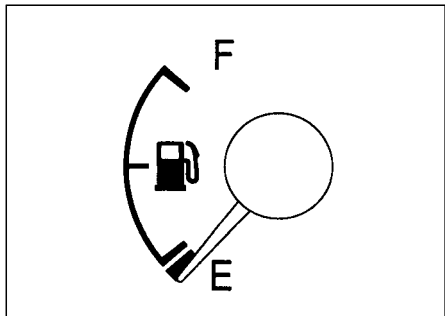

79F-05-010

This gauge gives an approximate indication of the amount of fuel in the fuel tank as shown in figure. "F" stands for full and "E" stands for empty.

If the indicator gets in the red zone, refill the tank as soon as possible.

**Note:**

*This vehicle has fuel gauge of new design. Even when the ignition switch is "OFF", the needle will not return to "E" position but will show the reading.*

**TEMPERATURE GAUGE**

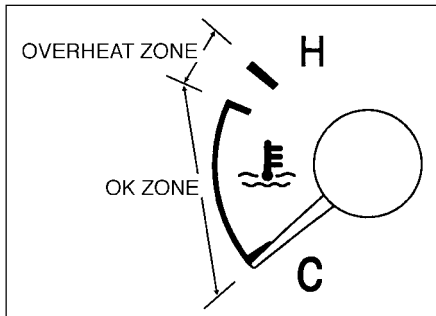

79F-05-011E

When the ignition switch is on, this gauge indicates the engine coolant temperature. Under normal driving conditions, the indicator should stay within the normal, acceptable temperature range between "H" and "C". If the indicator approaches "H", and maintains that reading, overheating is indicated. Follow the instructions for engine overheating in the EMERGENCY REMEDIES section.

<p><b>▲ CAUTION</b></p> <p><b>Continuing to drive the vehicle when engine overheating is indicated, can result in severe engine damage.</b></p>
---

**REAR WINDOW WIPER/WASHER SWITCH (if equipped)**

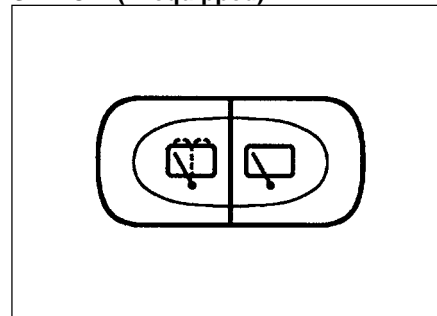

79F-05-012

With the ignition switch in the "ON" position, push the right side switch to turn on the rear wiper. To turn the wiper off, push the switch again.

To spray window washer fluid, hold in the left side switch. The rear wiper will automatically turn on. Washer fluid will stop spraying and the wiper will stop when you release the switch.

<p><b>▲ CAUTION</b></p> <p><b>Clear ice or snow from the rear window and rear wiper blade before using the rear wiper. Accumulated ice or snow could prevent the wiper blade from moving, causing damage to the wiper motor.</b></p>
--

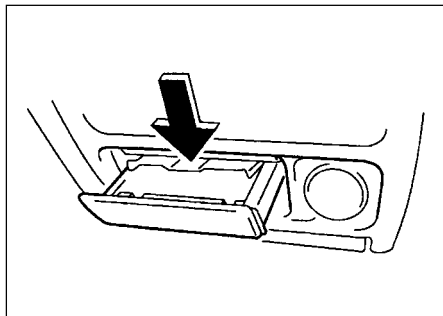
**ASHTRAY**

79F-05-013

To remove the front panel ashtray for cleaning, push down on the metal plate, and pull the ashtray completely out of its holder.

**▲ WARNING**

Make sure tobacco is fully extinguished before closing the ashtray. Never throw waste in the ashtray: it could create a fire hazard.

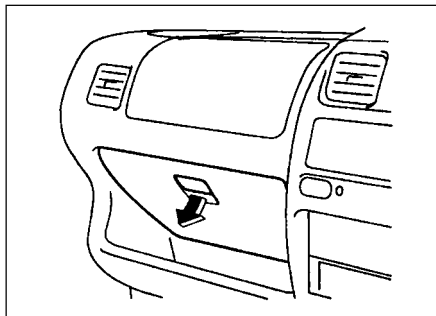
**GLOVE BOX**

79F-05-014

To open the glove box, pull the latch lever. To close it, push the lid until it latches securely.

**▲ WARNING**

Never drive with the glove box lid open. It could cause injury if an accident occurs.

**HEATING SYSTEM (if equipped)**

The heating system provides heating, demisting, and ventilation.

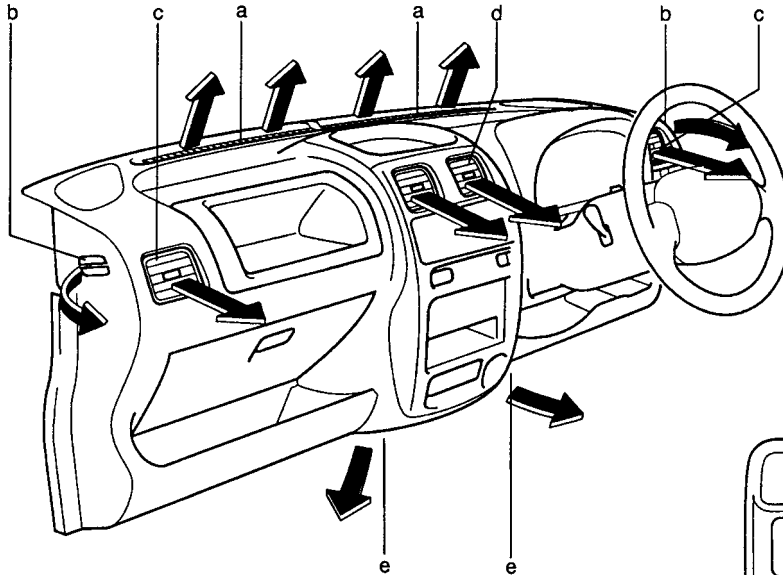

- a. Windscreen defroster outlet
- b. Side defroster outlet
- c. Side outlet
- d. Center outlet
- e. Floor outlet

79F-05-015

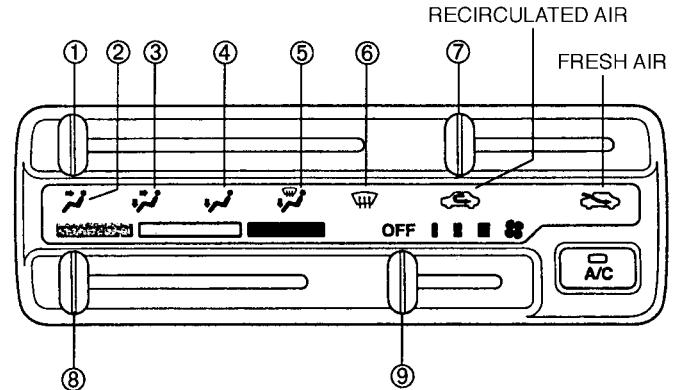

79F-05-016E

### Description of Controls

Function Lever ①: This lever is used to select one of the functions described below:



70F-03-029

**VENTILATION** ②: Temperature-controlled air comes out of the center and side air outlets.



70F-03-030

**BI-LEVEL** ③: Temperature-controlled air comes out of the floor outlets and cooler air comes out of the center and side outlets. When the temperature control lever is in the fully "COOL" position or fully "HOT" position, however, the air from the floor outlets and the air from the center and side outlets will be the same temperature.



70F-03-031

**HEAT** ④: Temperature-controlled air comes out of the floor outlets.



70F-03-032

**HEAT & DEFROST** ⑤: Temperature-controlled air comes out of the floor outlets, the windscreen defroster outlets, and the side defroster outlets.



70F-03-033

**DEFROST** ⑥: Temperature-controlled air comes out of the windscreen defroster outlets and the side defroster outlets.

**Air Intake Lever** ⑦: This lever is used to select between circulating outside air (FRESH AIR) or recirculating inside air (RECIRCULATED AIR).

**Temperature Control Lever** ⑧: This lever is used to control the temperature of the air that comes out of the air outlets.

**Fan switch** ⑨: This switch is used to turn on the fan and to select fan speed. There are four positions: OFF, LOW, MEDIUM and HIGH.

### SYSTEM OPERATING INSTRUCTIONS

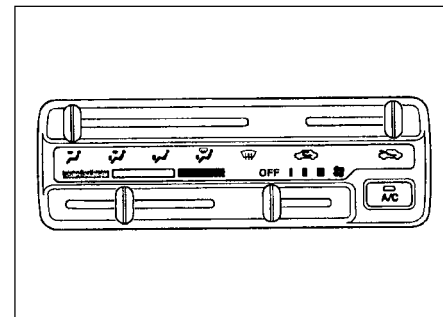

79F-05-017

#### Natural Ventilation

Move the function lever to "VENTILATION" and the air intake lever to "FRESH AIR", the temperature control lever to the desired temperature position, and the fan switch to "OFF". Fresh air will flow through the vehicle when it is moving.

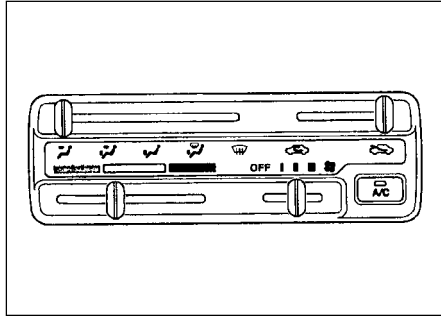

79F-05-018

**Forced Ventilation**

The lever settings are the same as for natural ventilation except you move the fan switch to a position other than "OFF".

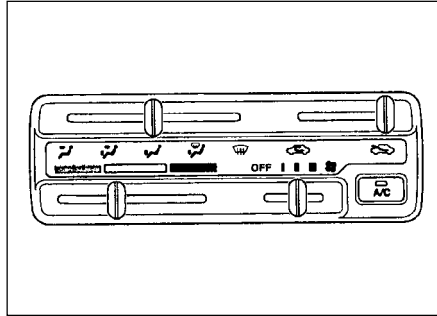

79F-05-019

**Normal Heating (Using outside air)**

Move the function lever to "HEAT" and the air intake lever to "FRESH AIR", the temperature control lever to the desired temperature position, and the fan switch to the desired fan speed position. Moving the fan switch to a higher fan speed position increases heating efficiency.

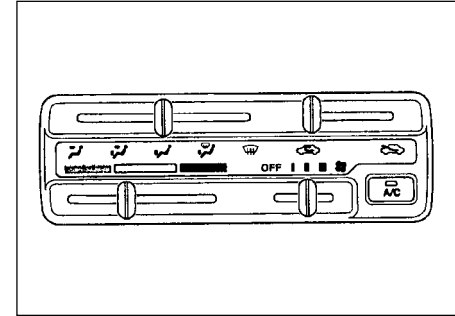

79F-05-020

**Quick Heating (Using recirculated air)**

The lever settings are the same as for normal heating except you move the air intake lever to "RECIRCULATED AIR". If you use this heating method for an extended period of time, the air in the vehicle can become contaminated and the windows can become misty. Therefore, use this method only for quick heating and change to the normal heating method as soon as possible.

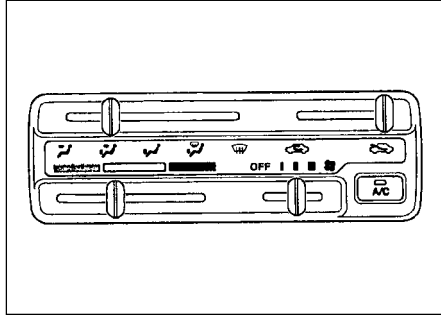

79F-05-021

### Cool Face/Warm Feet

Move the function lever to “BI-LEVEL” and the air intake lever to “FRESH AIR”, the temperature control lever to the desired temperature position, and the fan switch to the desired fan speed position. Unless the temperature control lever is in the fully “COOL” position or fully “HOT” position, the air that comes out of the center and side outlets will be cooler than the air that comes out of the floor outlets.

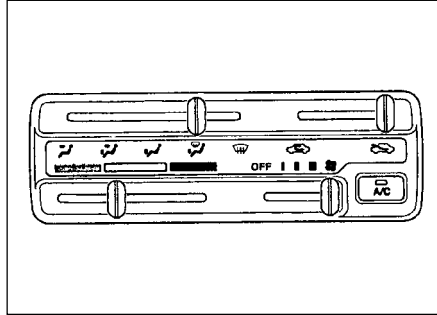

79F-05-022

### Defrosting/Warm Feet

Move the function lever to “HEAT & DEFROST” and the air intake lever to “FRESH AIR”, the temperature control lever to the desired temperature position, and the fan switch to “HIGH”. When the windscreen has become clear, move the fan switch to the desired fan speed position.

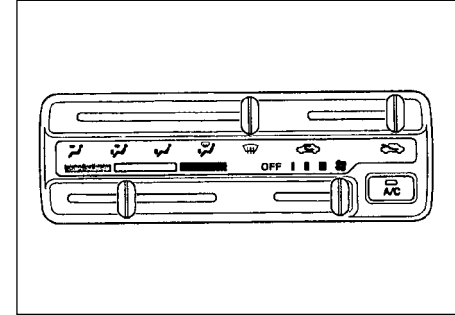

79F-05-023

### Defrosting

Move the function lever to “DEFROST” and the air intake lever to “FRESH AIR”, the temperature control lever to the desired temperature position, and the fan switch to “HIGH”. Moving the temperature control lever to a higher temperature position increases defrosting efficiency. When the windscreen has become clear, move the fan switch to the desired fan speed position.

## AIR CONDITIONING SYSTEM (if equipped)

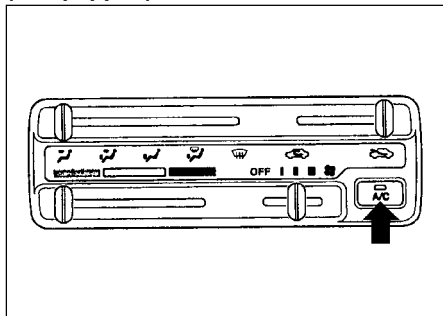

79F-05-024

If your vehicle is equipped with air conditioner, it has an A/C button located on the heater control panel. The air conditioning system can be used to provide cooling and dehumidifying, as described below. To turn on the air conditioning system, push in the A/C button and move the fan switch to a position other than "OFF". An indicator light will come on when the air conditioning system is on. To turn off the air conditioning system, push the A/C button again.

During operation of the air conditioner, you may notice slight changes in engine speed. These changes are normal, the system is designed so that the compressor turns on or off to maintain the desired temperature. Less operation of the compressor results in better fuel economy.

5-13

## SYSTEM OPERATING INSTRUCTIONS

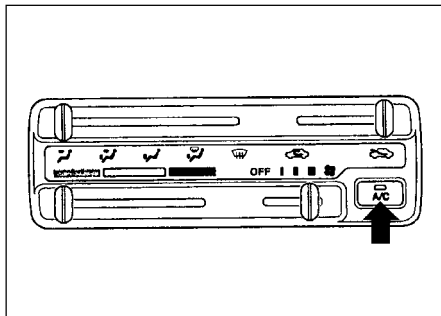

79F-05-025

**Normal Cooling (using outside air)**  
push in the A/C button, move the function lever to "VENTILATION", the air intake lever to "FRESH AIR", the temperature control lever to the "COOL" position, and the fan switch to the desired fan speed position. Moving the fan switch to a higher fan speed position increases cooling efficiency.

If the ambient temperature is high enough to cause insufficient cooling, use the "**Quick Cooling**" as following.

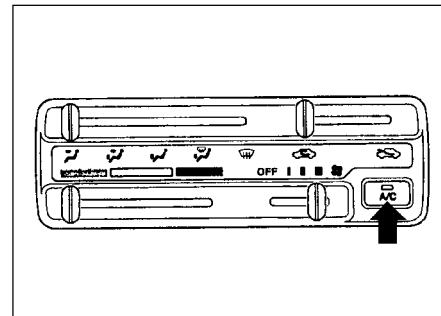

79F-05-026

**Quick Cooling (Using recirculated air)**  
The lever settings are the same as for normal cooling except you move the air intake lever to "RECIRCULATED AIR". If you use this cooling method for a extended period of time, the air in the vehicle can become contaminated. Therefore, you should occasionally move the air intake lever to "FRESH AIR".

**NOTE:**

*If your vehicle has been left in the sun with the windows closed, it will cool faster if you open the windows briefly while you operate the air conditioner with the air intake lever at "FRESH AIR" and the fan at high speed.*

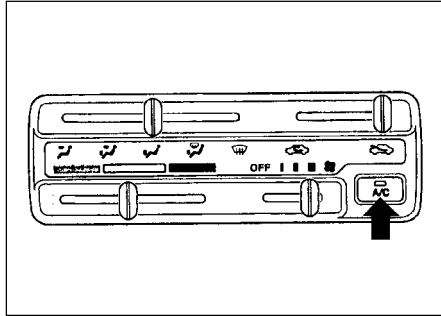

79F-05-027

### Dehumidifying

Push in the A/C button, move the function lever to the desired function position, the air intake lever to "FRESH AIR", the temperature control lever to the desired temperature position, and the fan switch to the desired fan speed position.

#### NOTE:

Because the air conditioner dehumidifies the air, turning it on will help keep the windows clear, even when blowing heated air using the DEMIST or HEATER & DEMIST functions.

#### NOTE:

There are two types of air conditioning systems used in MARUTI vehicles. One type uses refrigerant CFC-12, commonly called R-12; the other type uses the new refrigerant HFC-134a, commonly called R-134a. For each system, the correct refrigerant must be used. Your vehicle uses the refrigerant HFC-134a. To identify the system, a label that states "R134a" or "HFC134a" is stuck on the front side of the engine compartment.



79F-05-028

#### ▲ CAUTION

Using the wrong refrigerant may damage the air conditioning system. Use correct refrigerant only. Do not mix the two refrigerants.



**OTHER CONTROLS AND EQUIPMENT**

Parking Brake Lever .....	6-1
Pedals .....	6-2
Gear Lever .....	6-3
Fuel Filler Cap .....	6-3
Folding Seats .....	6-4
Sun Visor .....	6-6
Interior Light Switch .....	6-7
Assist Grips .....	6-7
Bonnet .....	6-8
Frame Hooks .....	6-9
Cup Holder (if equipped) .....	6-9
Tyre Changing Tools .....	6-10
Front Seat Back Pocket (if equipped) .....	6-11

## PARKING BRAKE LEVER

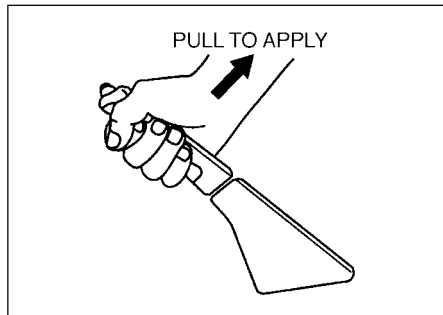

63B-06-001E

The parking brake lever is located between the seats. To apply the parking brake, hold the brake pedal down and pull the parking brake lever all the way up.

To release the parking brake, hold the brake pedal down, pull up slightly on the parking brake lever, push the button on the end of the lever with your thumb, and lower the lever to its original position.

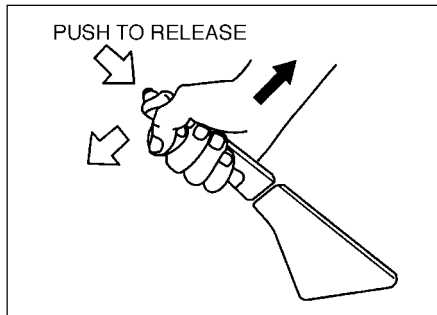

63B-06-002E

For automatic transmission vehicles, always apply the parking brake before moving the gear shift lever to the "P" (PARK) position. If you park on an incline and shift into "P" before applying the parking brake, the weight of the vehicle may make it difficult to shift out of "P" when you are ready to drive the vehicle.

When preparing to drive the vehicle, move the gearshift lever out of the "P" position before releasing the parking brake.

**⚠ WARNING**

- Never drive your vehicle with the parking brake on: rear brake effectiveness can be reduced from over heating, brake life may be shortened, or permanent brake damage may result.
- If the parking brake does not hold the vehicle securely or does not fully release, have your vehicle inspected immediately by an authorized MARUTI dealer.

**⚠ WARNING**

Always apply the parking brake fully before leaving your vehicle or it may move, causing injury or damage. When parking, make sure the gear shift lever for manual transmission is left in first gear or reverse and the gear shift lever for automatic transmission vehicles is in "P" (PARK). Remember, even though the transmission is in gear, you must always apply the parking brake fully.

## PEDALS

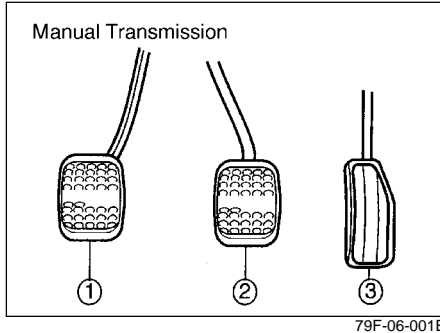

### Clutch Pedal ① (for manual transmission)

The clutch pedal is used to disengage the drive to the wheels when starting the engine, stopping, or shifting the transmission lever. Depressing the pedal disengages the clutch.

#### ⚠ CAUTION

Do not drive with your foot resting on the clutch pedal. It could result in excessive clutch wear, clutch damage, or unexpected loss of engine braking.

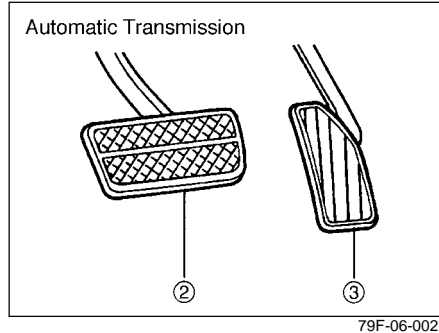

### Brake Pedal ②

Your MARUTI vehicle is equipped with front disc brakes and rear drum brakes. Depressing the brake pedal applies both sets of brakes.

You may hear occasional brake squeal when you apply the brakes. This is a normal condition caused by environmental factors such as cold, wet, snow, etc.

#### ⚠ WARNING

If brake squeal is excessive and occurs each time the brakes are applied, you should have the brakes checked by your MARUTI dealer.

#### ⚠ WARNING

Do not “ride” the brakes by applying them continuously or resting your foot on the pedal. This will result in overheating of the brakes which could cause unpredictable braking action, longer stopping distances, or permanent brake damage.

### Accelerator Pedal ③

This pedal controls the speed of the engine. Depressing the accelerator pedal increases power output and speed.

## GEAR LEVER

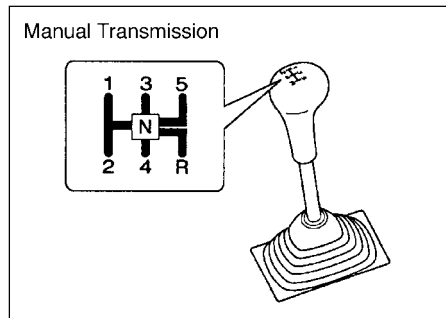

79F-06-003E

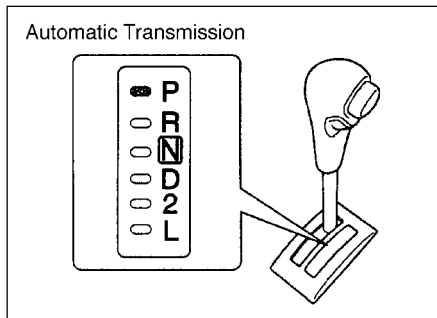

79F-06-004E

Your vehicle is equipped with either a manual transmission or automatic transmission. The gear change pattern for each transmission type is shown in the illustration. For details on how to use the transmission, refer to USING THE TRANSMISSION in the OPERATING YOUR VEHICLE section.

## FUEL FILLER CAP

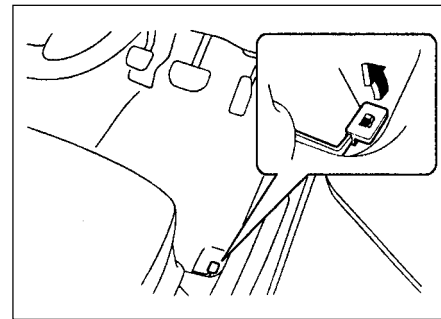

79F-06-005

The fuel filler cap is located on the left rear side of the vehicle. The fuel filler lid can be unlocked by pulling up the opener lever located on the outboard side of the driver's seat and locked by simply closing the lid.

**⚠ WARNING**

Remove the fuel filler cap slowly. The fuel may be under pressure and may spray out, causing injury.

**⚠ WARNING**

Petrol is extremely flammable. Do not smoke when refuelling, and make sure there are no open flames or sparks in the area.

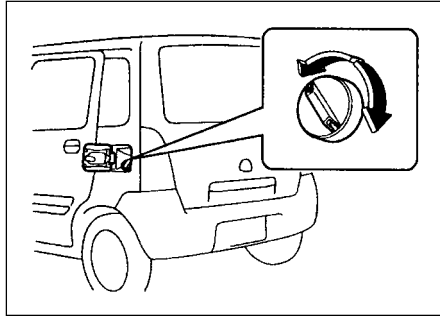

79F-06-006

The fuel tank filler cap has a "screw-on ratcheting type" feature.

- To remove - turn the cap counterclockwise. Turn the cap slowly to allow any residual pressure to escape.
- To install - turn the cap clockwise and tighten it securely until a "ratcheting" (clicking) sound is heard. The "ratcheting" sound indicates that the cap is on properly.

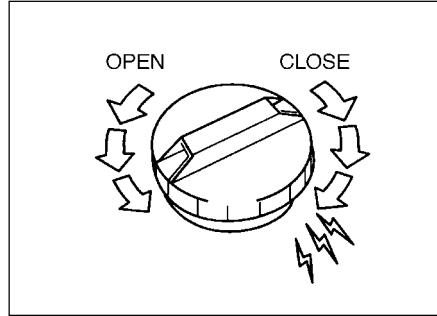

70F-04-008E

### ⚠ CAUTION

If you need to replace the fuel cap, use only a cap specified for your model. Using an improper fuel cap can cause a serious malfunction of the fuel system. You can get the correct replacement cap from your MARUTI dealer.

## FOLDING SEATS

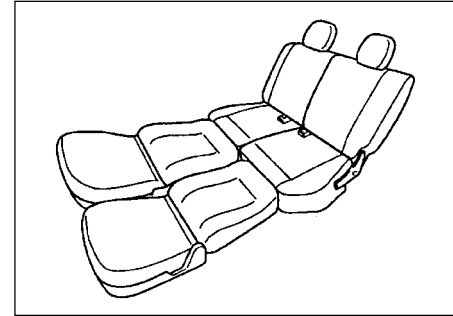

79F-06-007

### ⚠ WARNING

Seatbacks should always be in an upright position when driving, or seat belt effectiveness may be reduced. Seat belts are designed to offer maximum protection when seatbacks are in the fully upright position.

#### Flat Folding Front Seats (if equipped)

The front seats of your vehicle can be reclined fully back to provide a flat resting place. To fold back a front seat so it is flat:

- 1) Remove the front seat head restraints.
- 2) Recline the rear seatback(s) as far as they go while pulling up the two Release knobs on the top of the unsplit seat or

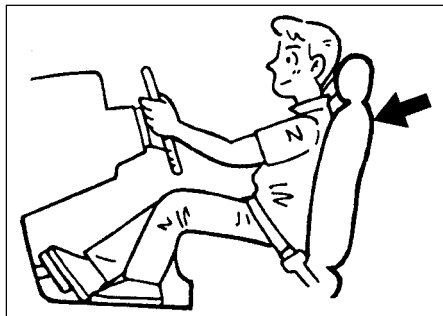

79F-06-008

by pulling the release lever on the back of the each split seat.

- 3) Slide the front seats fully forward.
- 4) Recline the front seatbacks fully.

**NOTE:**

Refer to the *ADJUSTABLE HEAD RESTRAINTS* section for details on how to remove the head restraint. Refer to the *FRONT SEAT ADJUSTMENT* section for details on how to slide the seat forward and how to recline the seatback.

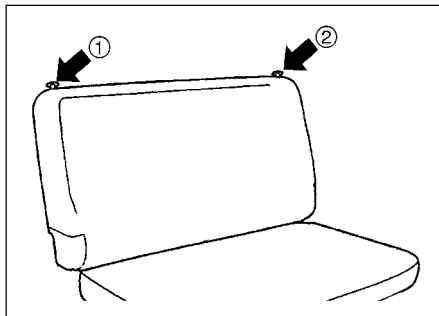

79F-03-012

**Folding Rear Seats**

The rear seats of your vehicle can be folded forward to provide additional luggage space.

To fold the rear seats forward:

1. Remove the rear seat head restraints (if equipped)
2. For unsplit rear seat:  
Pull up the two lock knobs (① and ②) on top of the seat simultaneously and fold the seatback forward.

For split rear seat:

Release lever on the back of each split seat, and fold the seatback forward until it is locked.

To raise the unsplit seatback lift it up and push it back until it locks into place.

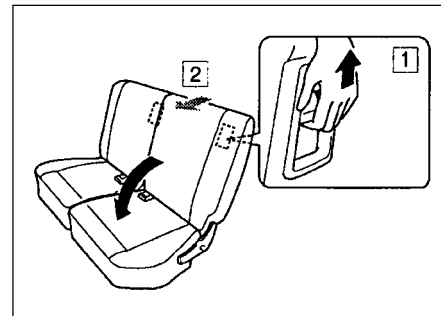

79F-06-009

To raise the split seatbacks pull the release lever forward and lift the seatbacks up and push them back until they lock into place.

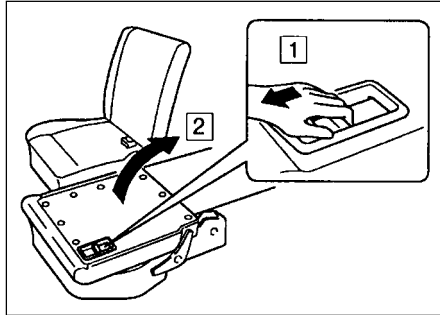

79F-06-010

**⚠ WARNING**

When returning a rear seat to the normal position, make sure that movement of the seatback is unobstructed and the seatback is securely latched.

**⚠ WARNING**

Luggage or other cargo should be stowed in the luggage compartment with the rear seat in an upright position, whenever possible. If you need to carry cargo in the passenger compartment with the rear seat back folded forward, be sure to secure the cargo or it may be thrown about, causing injury. Never pile cargo higher than the seatbacks.

## SUN VISOR

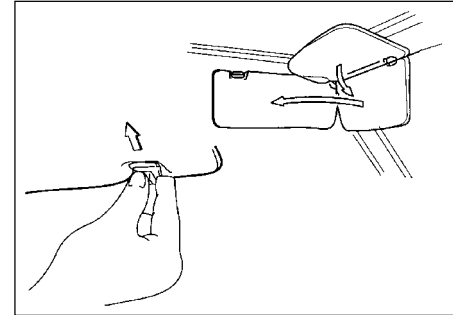

79F-06-011

The sun visors can be pulled down to block glare coming through the wind screen, or they can be unhooked and turned to the side to block glare coming through the side window.

**⚠ CAUTION**

When unhooking and hooking a sun visor, be sure to handle it by the hard plastic parts or the sun visor can be damaged.

## INTERIOR LIGHT SWITCH

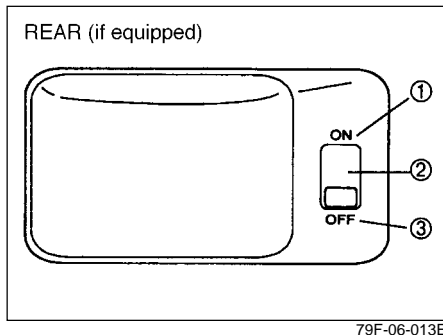
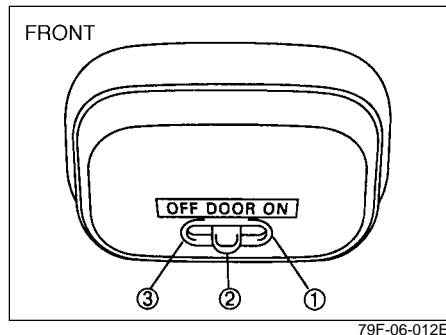

This light switch has three positions which function as described below:

- ① The light comes on and stays on regardless of whether the door is open or closed.
- ② The light comes on when the door is opened.
- ③ The light remains off even when the door is opened.

**NOTE:**

*Only front doors are involved in lighting operation of the interior light(s).*

## ASSIST GRIPS

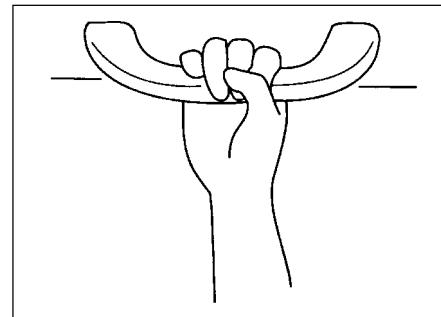

Assist grips are provided for passenger convenience.

**▲ WARNING**

**Do not hang items on the assist grips. They could obstruct the driver's view, resulting in an accident, or could be thrown about in an accident or abrupt manoeuvre, causing injury.**

## BONNET

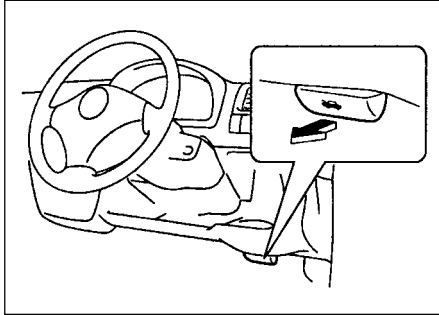

79F-06-014

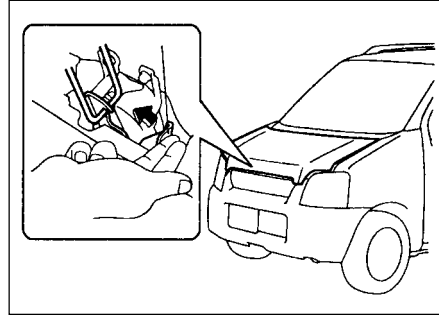

79F-06-015

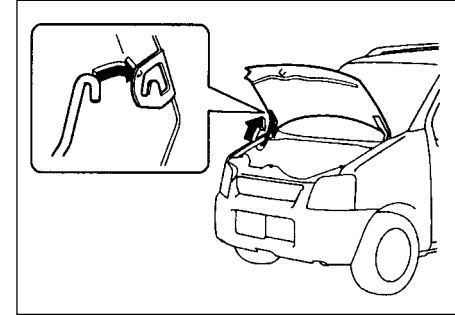

79F-06-016

To open the bonnet:

- 1) Pull the bonnet release handle located on the outboard side of the driver's side of the instrument panel. This will disengage the bonnet lock halfway.

- 2) Push the under-bonnet release lever sideways with your finger, as shown in the illustration. While pushing the lever, lift up the bonnet.

- 3) Continue to lift up the bonnet until it is high enough to support with the prop rod.

**▲ WARNING**

**Make sure the bonnet is fully closed and latched before driving. If it is not, it can fly up unexpectedly during driving, obstructing your view and resulting in an accident.**

## FRAME HOOKS

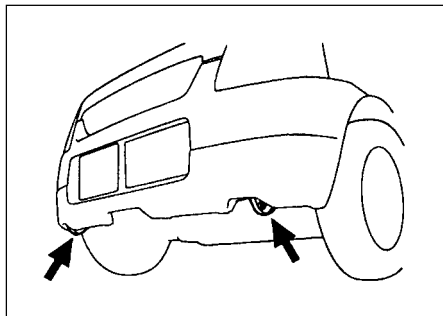

79F-06-017

Hooks are provided in both the front and rear of the vehicle for use in emergency situations. To tow your vehicle on the road or highway, follow the instruction of "TOWING" in "EMERGENCY SERVICE" section.

The shipping hook is provided on the rear of the vehicle for shipping use. Do not use the shipping hook for other than shipping purpose.

**▲ WARNING**

**Do not use these hooks to tow (or be towed by) another vehicle on the road or highway except in emergency situations.**

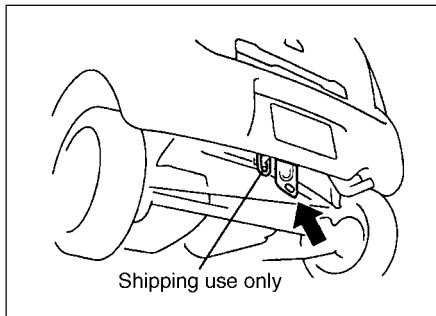

79F-06-018E

## CUP HOLDER (if equipped)

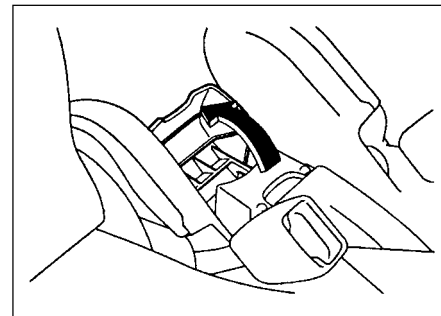

79F-06-019

The cup holder is provided on the right side of the dashboard and in the center console (if equipped).

**▲ WARNING**

**Do not use the cup holder to hold cups containing hot liquids, or objects other than cups. Objects in the cup holder may be thrown about during a sudden stop or impact, and could cause personal injury.**

## TYRE CHANGING TOOLS

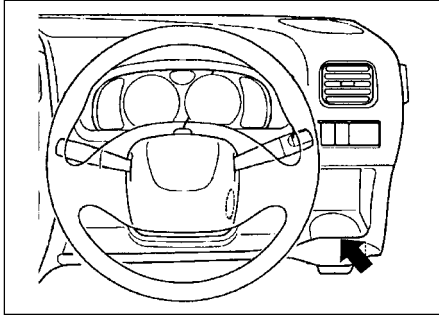

79F-06-020

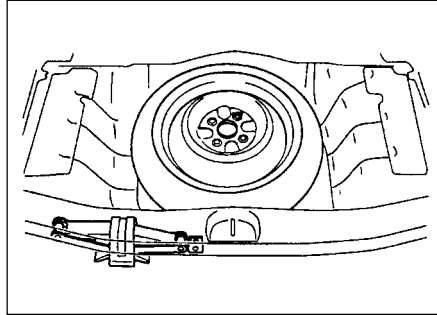

79F-06-021

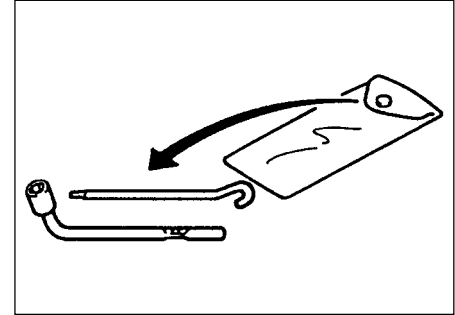

79F-06-022

The jack is stowed in the luggage compartment behind the rear seat.

To remove the jack, turn its shaft counterclockwise and pull the jack out of the storage bracket. To stow the jack, place it in the storage bracket and turn the shaft clockwise until the jack is securely held in place.

**NOTE:**

*If it is hard to loosen the wing bolt that secures the spare tyre, use the jack handle shaft as illustrated.*

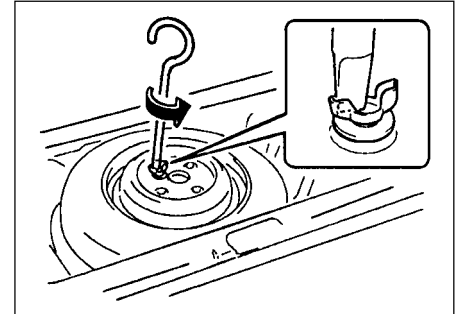

79F-06-023

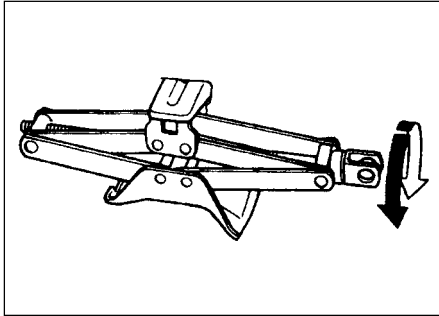

60G-06-010

**⚠ WARNING**

The jack should be used only to change wheels. It is important to read the jacking instructions in the EMERGENCY SERVICE section of this manual before attempting to use the jack.

**⚠ WARNING**

After using the jack, jack crank and wheel wrench, be sure to stow them securely or they can cause injury if an accident occurs.

**FRONT SEAT BACK POCKET (if equipped)**

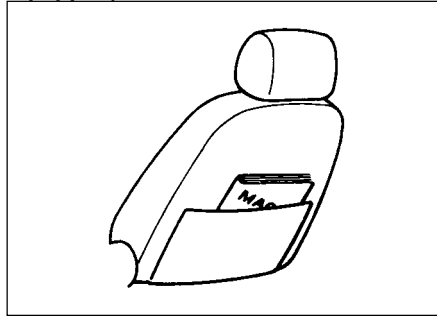

63B-06-022

This pocket is provided for holding light and soft things such as gloves, newspapers or magazines.

**⚠ WARNING**

Do not put hard or breakable objects in the pocket. If an accident occurs, objects such as bottles, cans, etc. can injure the occupants in the rear seat.

## OPERATING YOUR VEHICLE

Exhaust Gas Warning .....	7-1
Daily Inspection Checklist .....	7-1
Starting the Engine .....	7-2
Using the Transmission .....	7-3
Braking .....	7-5
Running-in .....	7-6
Catalytic Converter (if equipped) .....	7-7
Improving Fuel Economy .....	7-8
Trailer Towing .....	7-8

EXHAUST GAS WARNING

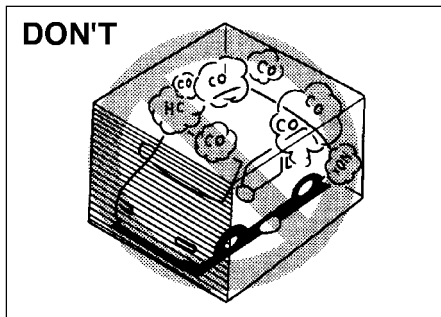

60G-07-001E

**⚠ WARNING**

Avoid breathing exhaust gases. Exhaust gases contain carbon monoxide, a potentially lethal gas that is colourless and odourless. Since carbon monoxide is difficult to detect by itself, be sure to take the following precautions to help prevent carbon monoxide from entering your vehicle.

- Do not leave the engine running in garages or other confined areas.
- Do not park with the engine running for a long period of time, even in an open area. If it is necessary to sit for a short time in a parked vehicle

**⚠ WARNING**

← with the engine running, make sure the air intake lever is set to "FRESH AIR" and the fan is at high speed.

- Avoid operating the vehicle with the rearend door open. If it is necessary to operate the vehicle with the rearend door open, make sure all the windows are closed and the fan is at high speed with the air intake lever set to "FRESH AIR".
- To allow proper operation of your vehicle's ventilation system, keep the air inlet grille in front of the windscreen clear of snow, leaves, or other obstructions at all times.
- Keep the exhaust tailpipe area clear of snow and other material to help reduce the buildup of exhaust gases under the vehicle. This is particularly important when parked in blizzard conditions.
- Have the exhaust system inspected periodically for damage and leaks. Any damage or leaks should be repaired immediately.

DAILY INSPECTION CHECKLIST



79F-07-001

**Before driving:**

- 1) Make sure that windows, mirrors, lights, and reflectors are clean and unobstructed.
- 2) Check the tyres.
- 3) Look for fluid and oil leaks.

**NOTE:**

*It is normal for water to drip from the air conditioning system after use.*

- 4) Adjust the seat/head restraint.
- 5) Check the brake pedal and the parking brake lever.
- 6) Adjust the mirrors.
- 7) Make sure that you and passengers have properly fastened your seat belts.
- 8) Make sure that all warning lights come on as the key is turned to the "ON" or "START" position.
- 9) Check all gauges.
- 10) Make sure that the brake fluid level warning light is off when the parking brake is released with the engine running.

## STARTING THE ENGINE

Once a week, or each time you fill your fuel tank, perform the following under-bonnet checks:

- 1) Engine oil level.
- 2) Coolant level.
- 3) Brake fluid level.
- 4) Windscreen washer fluid level.
- 5) Battery solution level.
- 6) Bonnet latch operation.  
Pull the bonnet release handle inside the vehicle. Make sure that you can not open the hood all the way without releasing the secondary latch. Be sure to close the hood securely after checking for proper operation. See "All Latches, Hinges & Locks" of "PERIODIC MAINTENANCE SCHEDULE" in the "INSPECTION AND MAINTENANCE" section for lubrication schedule.

### WARNING

**Make sure the bonnet is fully closed and latched before driving. If it is not, it can fly up unexpectedly during driving, obstructing your view and resulting in an accident.**

### Before starting the engine:

- 1) Make sure the parking brake is applied fully.
- 2) Manual Transmission - Shift into "N" (neutral) and depress the clutch pedal all the way to the floor. Hold it while starting the engine.

Automatic Transmission - Shift into "P" (Park) or "N" (Neutral). "P" is preferred. If you need to re-start the engine while the vehicle is moving, shift in to "N".

### WARNING

**Make sure that the parking brake is applied fully and the transmission is in Neutral (or Park for vehicles with an automatic transmission) before attempting to start the engine.**

### CAUTION

- Stop turning the starter immediately after the engine has started or the starter system can be damaged.
- Do not crank the engine for more than 15 seconds at a time. If the engine doesn't start on the first try, wait about 15 seconds before trying again.

### Starting a Cold Engine

Engine which is started after 6 hours should be treated as cold engine.

### For Electronic fuel injection models

- With your foot off the accelerator pedal, crank the engine by turning the ignition key to "START". Release the key when the engine starts.
- If the engine does not start after 15 seconds of cranking, wait about 15 seconds, then press down the accelerator pedal to 1/3 of its travel and try cranking the engine again. Release the key and accelerator pedal when the engine starts.
- If the engine still does not start, try holding the accelerator pedal all the way to the floor while cranking. This should clear the engine if it is flooded.

### Starting a Warm Engine

### For Electronic fuel injection models:

Use the same procedure as for "Starting a cold Engine".

USING THE TRANSMISSION

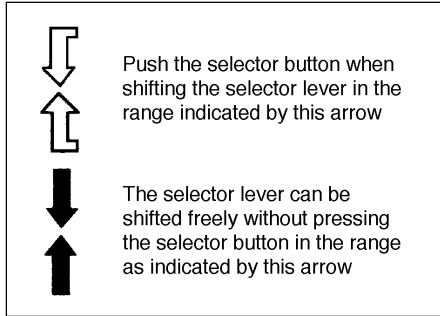

70F-05-003E

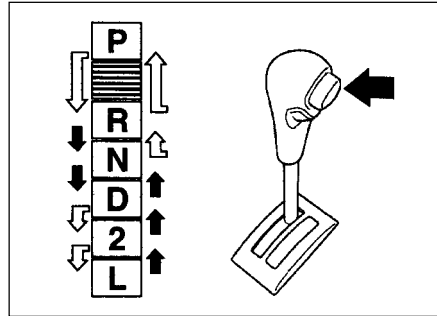

79F-07-003

**Automatic Transmission**

The garselector lever has a lock mechanism to help prevent accidental moving into or out of “P” (Park), into “R” (Reverse), from “D” (Drive) to “2” (Low 2) and from “2” (Low 2) to “L” (Low 1). To release the lock, push in the lock button on your side of the garselector lever before shifting.

**⚠ WARNING**

**Always depress the brake pedal before changing from “P” (Park) or “N” (Neutral) to a forward or reverse gear, to help prevent the vehicle from moving unexpectedly when you change.**

For all normal driving, put the garselector lever into “D” (Drive). Use the other garselector lever positions as described below:

**P (Park)**

Use this position to lock the transmission when the vehicle is parked or when starting the engine. Move into Park only when the vehicle is completely stationary.

**R (Reverse)**

Use this position to reverse the vehicle. Make sure that the vehicle is completely stationary before changing into Reverse.

**N (Neutral)**

Use this position for starting the engine if the engine stalls and you need to restart it while the vehicle is moving. You may also change into Neutral and depress the brake pedal to hold the vehicle stationary during idling.

**D (Drive)**

use this position for all normal driving.

With the selector in “D” range you can get an automatic downshift (change down) by pressing the accelerator pedal. The higher the vehicle speed is, the more you will need to press the accelerator pedal to get a downshift.

**2 (Low 2)**

Use this position to provide extra power when climbing hills, or to provide engine braking when going down hills.

**L (Low 1)**

Use this position to provide maximum power when climbing steep hills or driving through deep snow or mud, or to provide maximum engine braking when going down steep hills.

**NOTE:**

If the gear selector lever is shifted to the next lower gear position at a speed higher than the maximum allowable speed of the lower gear, the transmission can not be downshifted into the lower gear until the vehicle's speed slows down to the maximum speed of the gear.

**▲ CAUTION**

Be sure to take the following precautions to help avoid damage to the automatic transmission:

- Make sure that the vehicle is completely stationary before changing into "P" or "R".
- Do not change from "P" or "N" to "R", "D", "2", or "L" when the engine is running above idle speed.
- Do not rev the engine with the transmission in a drive position ("R", "D", "2", or "L") and the front wheels not moving.
- Do not use the accelerator to hold the vehicle on a hill. Use the vehicle's brakes.

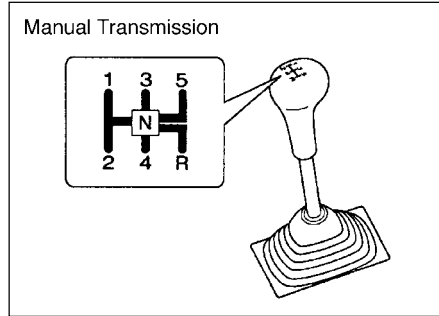

79F-06-003E

**Starting off**

To start off, depress and maintain pressure upon the clutch pedal and change into 1st gear. After releasing the parking brake, gradually release the clutch. When you hear a change in the engine's sound (speed), gently apply pressure to the accelerator to keep the engine sound (speed) constant whilst continuing to gradually release the clutch.

**Gear changing**

All forward gears are synchronized, which provides for quiet, easy changing. Always depress the clutch pedal fully before changing gears. The following table shows the maximum allowable speed for each gear.

GEAR	MAXIMUM SPEED
First	44 km/h
Second	80 km/h
Third	118 km/h
Fourth	Top Speed
Fifth	Top Speed

**▲ WARNING**

- Reduce your speed and change down to a lower gear before going down a long or steep hill. A lower gear will allow the engine to provide braking. Avoid riding the brakes or they may overheat, resulting in brake failure.
- When driving on slippery roads, be sure to slow down before changing down. Excessive and or sudden changes in engine speed may cause loss of traction, which could cause you to lose control.
- Make sure that the vehicle is completely stationary before you change into reverse.

## BRAKING

**▲ CAUTION**

- To help avoid clutch damage, do not use the clutch pedal as a footrest while driving or use the clutch to keep the vehicle stationary on a hill. Depress the clutch fully when changing gear.
- When changing gears or starting off, do not race the engine. Racing the engine can shorten engine life and prevent smooth operation.

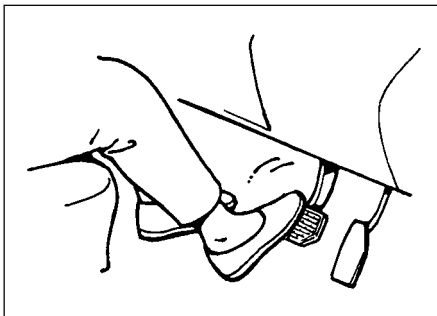

79F-07-004

The distance needed to bring any vehicle to a halt increases with the speed of the vehicle. The braking distance needed, for example, at 60 km/h will be approximately 4 times greater than the braking distance needed at 20 km/h. Start to brake the vehicle when there is plenty of distance between your vehicle and the stopping point, and slow down gradually.

**▲ WARNING**

If water gets into the brake drums, brake performance may become poor and unpredictable. After driving through water or washing the underside of the vehicle, test the brakes while driving at a slow speed to see if they have maintained their normal effectiveness. If the brakes are less effective than normal, dry them by repeatedly applying the brakes while driving slowly until the brakes have regained their normal effectiveness.

**Servo assisted brakes**

Your vehicle has servo assisted brakes which works with the assistance of engine vacuum.

**▲ WARNING**

**Do not switch off the engine while vehicle is in motion, for example, while driving down a hill as this will cause loss of vacuum assistance leading to reduction of braking efficiency substantially.**

If servo assistance is lost due to a stalled engine or other failures, the system is still fully operational on reserve power and you can bring the vehicle to a complete stop by pressing the brake pedal once and holding it down. The reserve power is partly used up each time you depress the brake pedal. Apply smooth and constant pressure to the pedal. Do not pump the pedal.

**▲ WARNING**

**Even without reserve power in the brake system, you can still stop the vehicle by pressing the brake pedal harder than normally required. However, the stopping distance may be longer.**

**▲ WARNING**

**On loose surface where the wheels can easily loose traction (such as gravel, etc.), the stopping distance required for your vehicle may be greater than for a comparable vehicle with a conventional brake system. Allow for extra stopping distance when driving on loose surfaces.**

**RUNNING-IN****▲ CAUTION**

The future performance and reliability of the engine depends on the care and restraint exercised during its early life. It is especially important to observe the following precautions during the initial 1000 km of vehicle operation.

- After starting, do not race the engine. Warm it up gradually.
- Avoid prolonged vehicle operation at a constant speed. Moving parts will bed in better if you vary your speed.
- Do not exceed 100 km/h.
- Start off from a stop slowly. Avoid full throttle starts.
- If possible, avoid hard braking, especially during the first 300 km of driving.
- Do not drive slowly with the transmission in a high gear.
- Drive the vehicle at moderate engine speeds.

**CATALYTIC CONVERTER**  
(if equipped)

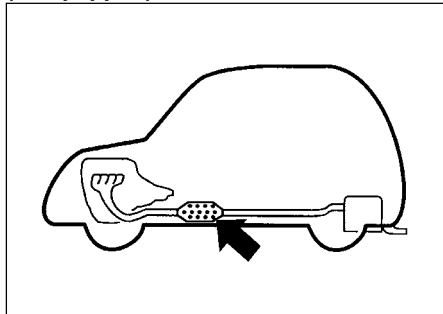

70F-05-005

The purpose of the catalytic converter installed on your vehicle is to convert exhaust pollutants to harmless water vapour, carbon dioxide, and nitrogen. Use of leaded fuel in vehicles equipped with catalytic converters is prohibited, because lead deactivates the pollutant-reducing components of the catalyst system.

It is very important to keep the engine properly tuned. Engine misfiring, which can result from an improperly tuned engine, may cause overheating of the catalyst. This may result in permanent heat damage to the catalyst and other vehicle components.

**▲ CAUTION**

To minimize the possibility of catalyst or other vehicle damage:

- Maintain the engine in the proper operating condition.
- In the event of an engine malfunction, particularly one involving engine misfire or other apparent loss of performance, have the vehicle serviced promptly.
- Do not turn off the engine or interrupt the ignition when the transmission is in gear and the vehicle is in motion.
- Do not try to start the engine by pushing or towing the vehicle, or coasting down a hill.
- Do not idle the engine with any spark plug wires disconnected or removed, such as during diagnostic testing.
- Do not idle the vehicle for prolonged periods if idling seems rough or there are other malfunctions.
- Do not allow the fuel tank to get near the empty level.

**DON'T**

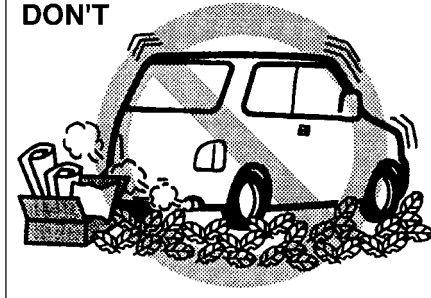

79F-07-005E

**▲ WARNING**

Be careful where you park and drive; the catalytic converter and other exhaust components can get very hot. As with any vehicle, do not park or operate this vehicle in areas where combustible materials such as dry grass or leaves can come in contact with a hot exhaust system.

## IMPROVING FUEL ECONOMY

The following instructions will help you improve fuel economy.

### Avoid excessive idling:

If you are to wait for more than a minute while you are parked, stop the engine and start it again later. When warming up a cold engine, allow the engine to idle until the temperature gauge pointer comes up to the "C" position. In this position, the engine is sufficiently warm for starting off.

### Avoid "fast" starts:

Fast starts away from lights or stop signs will consume fuel unnecessarily and shorten engine life. Start off slowly.

### Avoid unnecessary stops:

Avoid unnecessary deceleration and stopping. Try to maintain a slow, steady speed whenever possible. Slowing down and then accelerating again uses more fuel.

### Keep a steady cruising speed:

Keep as constant a speed as road and traffic conditions will permit.

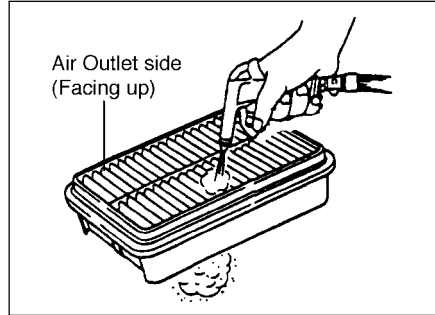

60G-09-010

### Keep the air cleaner clean:

A dirty air cleaner will cause the carburation system to supply too much fuel to the engine for the amount of air being supplied. The result is waste of fuel due to incomplete combustion.

### Keep weight to a minimum:

The heavier the load, the more fuel the vehicle consumes. Take out any luggage or cargo when it is not necessary.

### Keep tyre pressures correct:

Under-inflation of the tyres can waste fuel due to increased running resistance of the tyres. Keep your tyres inflated to the correct pressure shown on the label on the driver's side door or door lock pillar.

## TRAILER TOWING

Your MARUTI was originally designed to carry people and a normal amount of cargo, not to tow a trailer. Maruti does not recommend you use your vehicle to tow a trailer. Towing a trailer can adversely affect handling, durability, and fuel economy.



## DRIVING TIPS AND SAFE DRIVING

High Speed Driving .....	8-1
Driving on Hills .....	8-1
Driving on Slippery Roads .....	8-2
Do's and Don'ts for Safe Driving .....	8-3

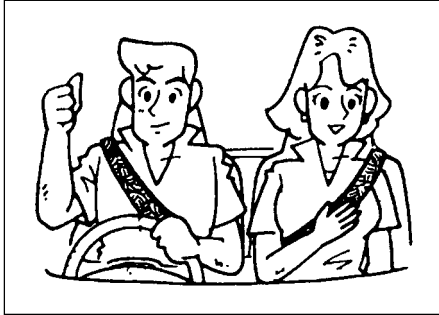

70F-06-001

### ▲ WARNING

- **Wear Your Seat Belts at All Times.** The driver and passengers should be properly restrained at all times, using the seatbelts provided. Refer to the “SEATBELTS” section for instructions on proper use of the seat belts.
- **Never drive while under the influence of alcohol or other drugs.** Alcohol and drugs can seriously impair your ability to drive safely, greatly increasing the risk of injury to yourself and others. You should also avoid driving when you are tired, sick, irritated, or under stress.

## HIGH-SPEED DRIVING

When driving at a high-speed, pay attention to the following:

- Stopping distance progressively increases with vehicle speed. Apply the brakes far enough ahead of the stopping point to allow for the extra stopping distance.
- On rainy days, “Aquaplaning” can occur. “Aquaplaning” is the loss of direct contact between the road surface and the vehicle’s tyres due to a water film forming between them. Steering or braking the vehicle while “Aquaplaning” can be very difficult, and loss of control can occur. Keep speed down when the road surface is wet.
- At high speeds, the vehicle may be affected by side winds. Therefore, reduce speed and be prepared for unexpected buffeting, which can occur at the exits of tunnels, when passing by a cut of a hill, or when being overtaken by large vehicles, etc.

## DRIVING ON HILLS

- When climbing steep hills, the vehicle may begin to slow down and show a lack of power. If this happens, you should change to a lower gear so that the engine will again be operating in its normal power range. Change rapidly to prevent the vehicle from losing momentum.
- When driving down a hill, the engine should be used for braking by shifting to next lower gear (Do this with EITHER an automatic or manual transmission).

### ▲ WARNING

**Try not to hold the brake pedal down too long or too often while going down a steep or long hill. This could cause the brakes to overheat, resulting in reduced braking efficiency. Failure to take this precaution could result in loss of vehicle control.**

### ▲ CAUTION

**When descending a down hill, NEVER turn the ignition key to the “OFF” position. Emission control system and automatic transmission (if equipped) damage may result.**

## DRIVING ON SLIPPERY ROADS

Under wet road conditions you should drive at a lower speed than on dry roads due to possible slippage of tyres during braking. When driving on icy, snowcovered, or muddy roads, reduce your speed and avoid sudden acceleration, abrupt braking, or sharp steering movements.

### Snow Chains

If you must use snow chains to increase tyre traction, observe the following precautions:

- Use cable type chains.
- Choose a safe place away from traffic to install the chains.
- When installing the chains carefully follow the manufacturer's instructions.
- Install the chains on the front tyres.
- With the chains on, drive only at slow and moderate speeds.
- If the chain hits the vehicle body while driving, stop at a safe place and retighten it as soon as possible.
- If snow and/or ice on the road disappear, remove the chains as soon as possible.
- **If Your Vehicle Gets Stuck**  
If your vehicle gets stuck in snow, mud, or sand, follow the directions below:

- 1) Change back and forth between a

69

forward range (or first gear for manual transmission) and reverse. This will create a rocking motion which may give you enough momentum to free the vehicle. Press gently on the accelerator to keep wheel spin to a minimum. Remove your foot from the accelerator while changing gear.

Do not race the engine. Excessive wheel spin will cause the tyres to dig deeper, making it more difficult to free the vehicle.

- 2) If your vehicle remains stuck after a few minutes of rocking, get another vehicle to pull you out.

### ⚠ WARNING

**Do not allow anyone to stand near the vehicle when you are rocking it, and do not spin the wheels faster than an indicated 40 km/h on the speedometer. Personal injury and/or vehicle damage may result from spinning the wheels too fast.**

### ⚠ CAUTION

**Do not continue rocking the vehicle for more than a few minutes. Prolonged rocking can cause engine overheating or transmission damage.**

### ⚠ WARNING

- **Make sure your tyres are in good condition and always maintain the specified tyre pressure. Refer to "TYRES" in the "INSPECTION AND MAINTENANCE" section for details.**
- **Do not use tyres other than those specified by MARUTI. never use different sizes or types of tyres on the front and rear wheels. For information regarding the specified tyres, refer to the "SPECIFICATIONS" section.**
- **Never use oversized tyres or special shock absorbers and springs to raise (jack up) your vehicle. This will change the handling characteristics.**
- **After driving through water, test the brakes while driving at a slow speed to see if they have maintained their normal effectiveness. If the brakes are less effective than normal, dry them by repeatedly applying the brakes while driving slowly until the brakes have regained their normal effectiveness.**

**DO'S AND DON'TS FOR SAFE DRIVING**

Exercise care in handling your vehicle. Be conscious of not only your own safety but also the safety of others on the road, and thus enjoy the best and most comfortable driving experience.

This section contains basic rules for safe driving. Read it carefully for good understanding of the content so that you can enjoy safe and pleasant driving in your Maruti vehicle.

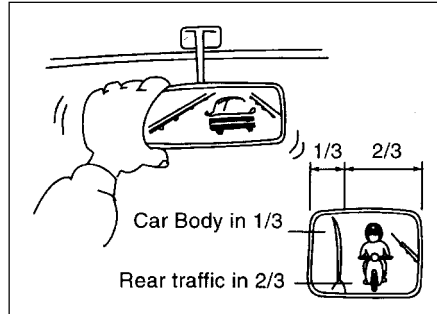

72F-08-002

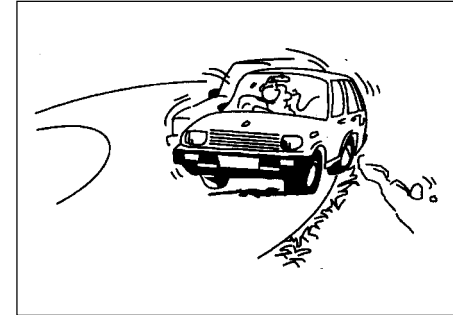

72F-08-008

**Starting**

1. Adjust the driver's seat for the proper driving posture.
2. Adjust the rear view mirror so as to obtain the best possible rear view.
3. Before moving off, look forward and back to confirm safety.
4. Don't start quickly, for it is dangerous and wastes fuel.

**General driving**

1. Be sure to stop before the stop light and stop sign. When moving into the intersection without any traffic lights or signs, drive slowly to confirm safety.

2. Always follow other vehicles at a safe distance in order to prevent a rear-end collision, should the vehicle ahead make a sudden stop.
3. Turn ON the turn signal at least 30 meters before making a turn or changing the lane so as not to be hit from behind.
4. Before entering a corner, decelerate to a safe speed. Don't apply brakes during cornering, or a cornering skid may occur.
5. When overtaking other vehicles, watch out for the oncoming vehicle and carefully confirm the safety.
6. Don't attempt zigzag driving which will hinder your control over the vehicle and cause an accident.

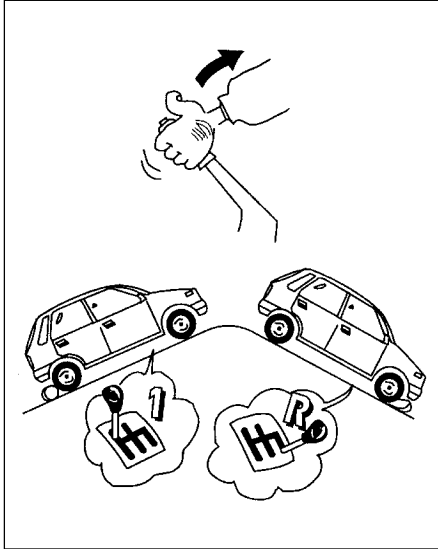

72F-08-011

### Braking

1. Use the parking brake when parking your vehicle and shift the gear shift lever into the first gear or reverse gear position for the sake of safety.
2. Don't use handbraking unless unavoidable. It causes the vehicle to skid and a rearend collision occur. It is



72F-08-012

especially dangerous when the tyres are worn, for they allow a larger skid.

Use foot brake in three stages

- (1) Warn the vehicle behind you
  - (2) Gradually apply the brake.
  - (3) Bring the vehicle to a halt.
3. When driving on a downhill, try not to apply the brake but use the engine brake effectively. Overuse of the footbrake may result in total brake failure.
  4. Avoid reckless high speed driving and try to drive at a safe speed suitable for the road conditions while maintaining a constant speed.

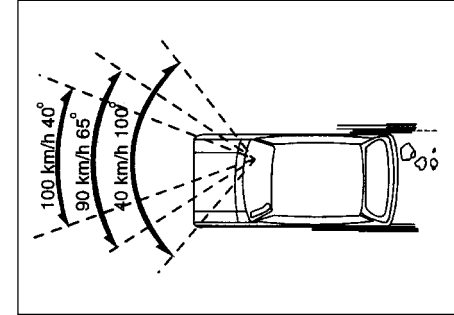

72F-08-015

5. The higher the speed, the narrower the driver's visual range becomes. In such a state, it is difficult to anticipate any hazard and the driver feels much fatigued.
6. Never do sharp handling during high speed driving. You will lose your control over your vehicle.
7. When overtaking or changing the lane while driving at a high speed, keep an ample vehicle-to-vehicle distance.

### Long distance driving

1. Be sure to perform safety checks before starting a trip.
2. Take rest at certain intervals to prevent an accident which may occur when you are sleepy or tired.



72F-08-020

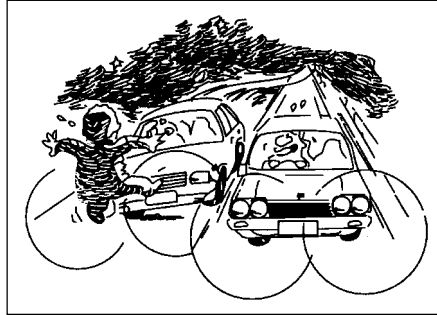

72F-08-021

**Night time driving**

1. Drive more slowly at night than in the daytime, for the visual range is restricted at night.
2. Don't overtake other vehicles at night. Darkness bothers your sense of speed and hinders your judgement on the vehicle-to-vehicle distance.
3. Don't use the high headlight beam unless its use is inevitable. Its dazzle may blitz the driver of the oncoming vehicle, thus causing an accident.
4. Always keep the window glasses clean. Don't operate the windshield wiper when the windshield glass is dry or the wiper blade and glass may get damaged.

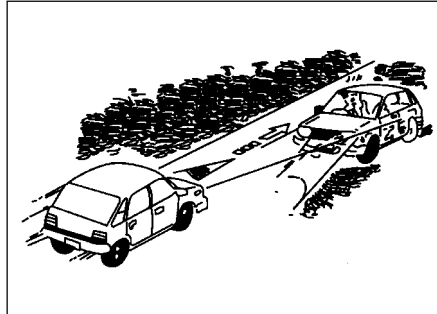

72F-08-022

**MARGIN FOR SAFETY**

It is important to allow yourself a margin for safety during driving so that you can cope with erroneous or unexpected driving of other drivers. For that, observe the following.

- Drive at a safe speed.
- Maintain a sufficient distance between your vehicle and the vehicle ahead.
- Don't force yourself to overtake other vehicles.
- Don't make quick start, hard steering or sudden stops.
- Allow an ample time in the driving schedule.
- Observe traffic rules and regulations.

**CONCLUSION**

A perfect driver does not exist. The endeavour of every motorist should be to strive for perfection. Safety consciousness not only ensures your safety and the safety of other road users, it also helps reduce the wear and tear on your vehicle, prolongs its life, gives more mileage and ensures a comfortable driving experience.

**Follow the do's and don'ts listed, and driving will never be the same again.**

## INSPECTION AND MAINTENANCE

Periodic Maintenance Schedule .....	9-1
Drive Belt .....	9-6
Engine Oil and Filter .....	9-7
Gear Oil .....	9-10
Automatic Transmission Fluid .....	9-11
Engine Coolant .....	9-12
Windscreen Washer Fluid .....	9-14
Air Cleaner .....	9-14
Spark Plugs .....	9-15
Brakes .....	9-16
Steering .....	9-18
Clutch Pedal .....	9-18
Tyres .....	9-19
Battery .....	9-22
Fuses .....	9-22
Bulb Replacement .....	9-25
Wiper Blades .....	9-28

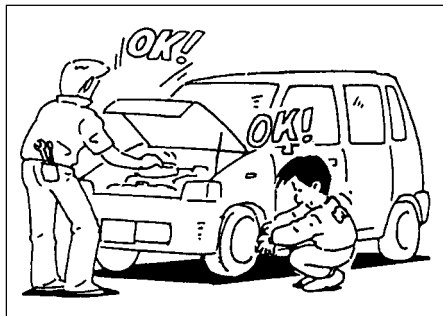

79F-07-002

### ▲ WARNING

You should take extreme care when working on your vehicle to prevent accidental injury. Here are a few precautions that you should be especially careful to observe:

- Do not leave the engine running in garages or other confined areas.
- When the engine is running, keep hands, clothing, tools, and other objects away from the fan and water pump belt. Even though the fan may not be moving, it can automatically turn on without warning. →

### ▲ WARNING

- ← • When it is necessary to do service work with the engine running, make sure that the parking brake is applied fully and the transmission is in Neutral (for manual transmission vehicles) or Park (for automatic transmission vehicles).
- Do not touch ignition wires or other ignition system parts when starting the engine or when the engine is running, or you could receive an electric shock.
- Be careful not to touch a hot engine, exhaust manifold and pipes, muffler, radiator and water hoses.
- Do not allow smoking, sparks, or flames around gasoline or the battery. Flammable fumes are present.
- Do not get under your vehicle if it is supported only with the portable jack provided in your vehicle.
- Be careful not to cause accidental short circuits between the positive and negative battery terminals.
- Keep used oil, coolant, and other fluids away from children and pets. Dispose of used fluids properly; never pour them on the ground, into sewers, etc.

## PERIODIC MAINTENANCE SCHEDULE

The following table shows when regular maintenance on your vehicle is required. This table shows in kilometres and months when inspections, adjustments, lubrication and other services should be performed.

### ▲ WARNING

Maruti recommends that maintenance on your Maruti vehicle be performed by Maruti Authorised Dealer/Service Station.

### ▲ CAUTION

Whenever it becomes necessary to replace parts on your vehicle, it is recommended that you use **MARUTI GENUINE PARTS (MGP)**.

**A....Adjust.**

**T....Tighten to specified torque.**

**R....Replace or change.**

**L....Lubricate.**

**I....Inspect and correct or replace if necessary.**

**C....Clean.**

**O....Rotate**

*Note:*

*This table includes services as scheduled up to 80,000 km mileage. Beyond 80,000 km, carry out the same services at the same intervals respectively.*

Interval: This interval should be judged by odometer reading or months, whichever comes first.	km (x 1,000) months	FREE INSPECTIONS			PERIODIC MAINTENANCE SERVICE AT COST							
		1	5	10	20	30	40	50	60	70	80	
		1	6	12	24	36	48	60	72	84	96	
<b>ENGINE</b>												
1. Water pump drive belt (tension, wear)		A	I	I	I	I	I	I	R	A	I	
2. Engine coolant (level, leakage)		I	I	I	R	I	R	I	R	I	R	
3. Engine oil (API GRADE SF, SG, SH) & Oil filter		R	I	R	R	R	R	R	R	R	R	
4. Cooling system hoses and connections (leakage, damage)		I	I	I	I	I	I	I	I	I	I	
5. Engine bolts (All cylinder head and manifold fixings)		-	-	T	-	T	-	T	-	T	-	
6. Engine mounting (loose, damage)		-	-	T	-	T	-	T	-	T	-	
7. Valve clearance		-	A	-	A	-	A	-	A	-	A	
8. Camshaft timing belt (damage, wear)		-	-	-	I	-	I	-	I	-	I	
		Replace every 1,00,000 km										
9. Exhaust system (noise, leakage or otherwise defective)		-	I	-	I	-	I	-	I	-	I	
10. Positive crankcase ventilation System (Hoses, connections and valve)		-	I	-	I	-	I	-	I	-	I	
<b>IGNITION</b>												
1. Ignition wiring, (damage, deterioration)		-	-	-	I	-	I	-	I	-	I	
2. Spark plugs (clean and adjust the gap)		-	-	I	R	I	R	I	R	I	R	

## INSPECTION AND MAINTENANCE

79F-74E

Interval: This interval should be judged by odometer reading or months, whichever comes first.	km (x 1,000) months	FREE INSPECTIONS			PERIODIC MAINTENANCE SERVICE AT COST							
		1	5	10	20	30	40	50	60	70	80	
		1	6	12	24	36	48	60	72	84	96	
<b>FUEL</b>												
1. Air cleaner	Paved-road Dusty condition	Clean every 5,000 km. Replace every 40,000 km. Clean every 2,500 km or as required. Replace every 40,000 km. More frequent replacement if dust condition is severe.										
2. Accelerator cable and Throttle shafts		–	I&L	I&L	I&L	I&L	I&L	I&L	I&L	I&L	I&L	
3. Fuel tank cap, fuel lines & connections(leakage,damage)		–	I	–	–	–	I	–	–	–	I	
4. Fuel filter (leakage)		I	I	I	I	I	R	I	I	I	R	
<b>CLUTCH AND TRANSMISSION</b>												
1. Clutch pedal (play)		I	I	I	I	I	I	I	I	I	I	
2. Clutch slipping (dragging or excessive damage)		I	I	I	I	I	I	I	I	I	I	
3. Manual Transmission/Transfer and Differential oil (level, leakage)		I	I	I	R	I	R	I	R	I	R	
4. Automatic Transmission Fluid (level, replacement)		I	I	I	I	I	I	I	I	I	R	
5. Hose, Automatic Transmission Fluid		I	I	I	I	I	I	I	I	I	R	
<b>DRIVE SHAFTS</b>												
1. Drive shafts boots (bent of boots damage)		–	I	I	I	I	I	I	I	I	I	
<b>BRAKE</b>												
1. Brake fluid (level, leakage)		I	I	I	R	I	R	I	R	I	R	
2. Brake pedal (pedal-to-wall clearance)		I	I	I	I	I	I	I	I	I	I	
3. Parking brake lever and cable (play, damage)		I	I	I	I	I	I	I	I	I	I	
4. a. Brake discs and pads, (wear)		–	I	I	I	I	I	I	I	I	I	
b. Brake drums & shoes		–	–	I	I	I	I	I	I	I	I	
5. Master cylinder and wheel cylinder or calliper (oil leakage, boot kit)		I	I	I	I	I	R	I	I	I	R	
6. Brake hoses and pipes (leakage, damage)		I	I	I	I	I	I	I	I	I	I	

Interval: This interval should be judged by odometer reading or months, whichever comes first.	km (x 1,000) months	FREE INSPECTIONS			PERIODIC MAINTENANCE SERVICE AT COST							
		1	5	10	20	30	40	50	60	70	80	
		1	6	12	24	36	48	60	72	84	96	
<b>WHEEL</b>												
1. Tyres (air pressure, abnormal wear, crack, ROTATION)		Rotate and inspect every 5,000 km										
2. Wheels (damage)												
3. Front wheel bearings (loose, damage)		-										
4. Rear wheel bearings (loose, damage)		-										
<b>FRONT AND REAR SUSPENSION</b>												
1. Suspension strut (oil leakage, damage)												
2. Suspension arms and knuckle supports (loose,damage)		-										
3. Rear spring (damage)		-										
4. Shock absorbers (oil leakage, damage)												
5. All bolts and nuts (loose)		-	T	T	T	T	T	T	T	T	T	
6. Suspension arms and Tension rods		-										
<b>STEERING</b>												
1. Steering wheel (play, loose)												
2. All rods and arms (loose, damage, wear)												
<b>ELECTRICAL</b>												
1. Battery electrolyte (level, leakage)												
2. Wiring harness connection (looseness, damage)		-										
3. Lighting system (operation, stains, damage)												
4. Horn (operation)												
5. System voltage		-										
<b>BODY</b>												
1. All chassis bolts and nuts (tighten)		-		T	T	T	T	T	T	T	T	
2. All Latches, Hinges & Locks (function)			I&L	I&L	I&L	I&L	I&L	I&L	I&L	I&L	I&L	

## INSPECTION AND MAINTENANCE

79F-74E

Interval: This interval should be judged by odometer reading or months, whichever comes first.	km (x 1,000) months	FREE INSPECTIONS			PERIODIC MAINTENANCE SERVICE AT COST							
		1	5	10	20	30	40	50	60	70	80	
		1	6	12	24	36	48	60	72	84	96	
<b>ROAD TEST</b>												
1. Operation of Brakes, Gear shifting & speedometer												
2. Body and Chassis noise												
<b>AIR CONDITIONER (if equipped)</b>												
1. Check belt tension												
2. Check Receiver Drier bubbles.												
3. Tighten compressor mounting bolts		-	T	T	T	T	T	T	T	T	T	
4. Check all hose joints, tighten if necessary												
5. Check functioning of Recirc flap												
6. Clean condenser with low pressure water		-	C	C	C	C	C	C	C	C	C	
7. Check belt for frayed edges, change if necessary		-										
8. Check all mounting bolts		-										

### WARNING

The rear shock absorbers are filled with high pressure gas. Never attempt to disassemble it or throw it into a fire. Avoid storing it near a heater or heating device. When scrapping the absorber, the gas must be released from the absorber safely. Ask your dealer for assistance.

## DRIVE BELT

**⚠ WARNING**

- All maintenance should be carried out with the ignition switch in the "OFF" position and the car parked securely on the level ground unless otherwise specified.
- If you are in any way unsure of your ability to undertake a task, then do not start it but contact your Maruti dealer to perform the work for you.

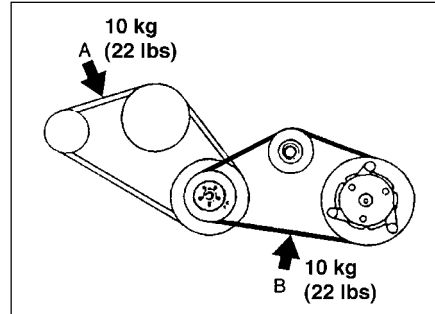

79F-09-001E

**⚠ WARNING**

**When the engine is running, keep hands, hair, clothing, tools, etc. away from the fan and drive belt. Even though the fan may not be moving, it can automatically turn on without warning.**

Water pump belt (A)	6 - 7 mm
Air conditioner belt (B)	8 - 9 mm

The belt should also be examined to ensure that it is not damaged. If the belt needs to be replaced or adjusted, have it done by your MARUTI dealer.

Make sure the drive belt tension is correct. If the belt is too loose, insufficient battery charging, engine overheating, or excessive belt wear can result. When you press the belt with your thumb midway between the pulleys, the belt deflection should be within the specification below.

## ENGINE OIL AND FILTER

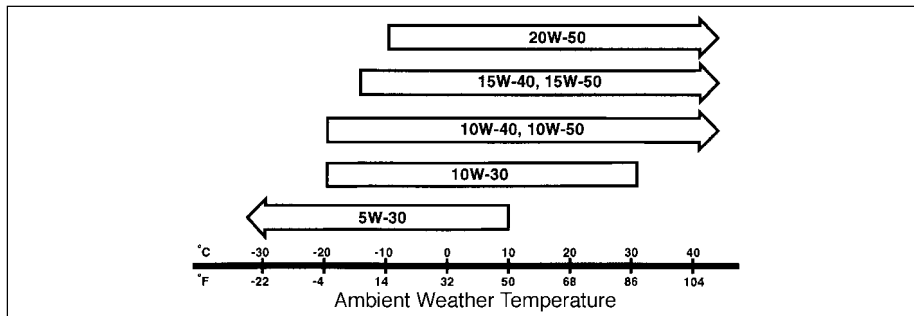

70F-07-004E

**Specified oil**

Be sure that the engine oil you use comes under the API classification of SF, SG or SH. Select the appropriate oil viscosity according to the above chart.

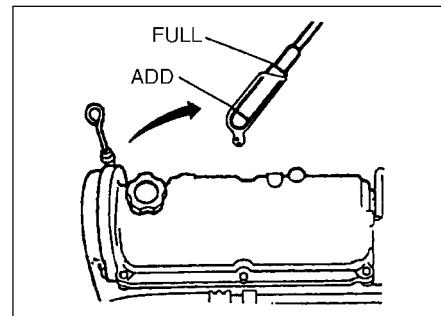

79F-09-002E

**Oil Level Check**

It is important to keep the engine oil at the correct level for proper lubrication of your vehicle's engine. Check the oil level with the vehicle on a level surface. The oil level indication may be inaccurate if the vehicle is on a slope. The oil level should be checked either before starting the engine or at least 5 minutes after stopping the engine.

Pull out the oil dipstick, wipe oil off with a clean cloth, insert the dipstick all the way into the engine, then remove it again. The oil on the stick should be between the upper and lower limits shown on the stick. If the oil level indication is near the lower limit, add enough oil to raise the level to the upper limit.

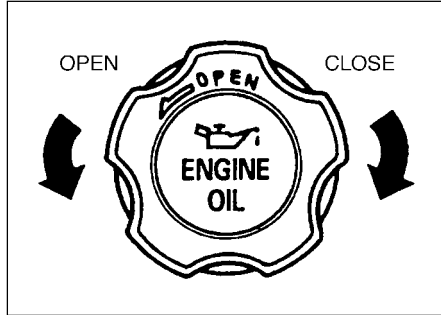

79F-09-003E

### Refilling

Remove the oil filler cap and pour oil slowly through the filler hole to bring the oil level to the upper limit on the dipstick. Be careful not to overfill. Too much oil is almost as bad as too little oil. After refilling, start the engine and allow it to idle for about a minute. Stop the engine, wait for five minutes and check the oil level again.

### Changing Engine Oil and Filter

Drain the engine oil while the engine is still warm.

- 1) Remove the oil filler cap.
- 2) Place a drain pan under the drain plug.
- 3) Using the correct spanner remove the drain plug and drain out the engine oil.

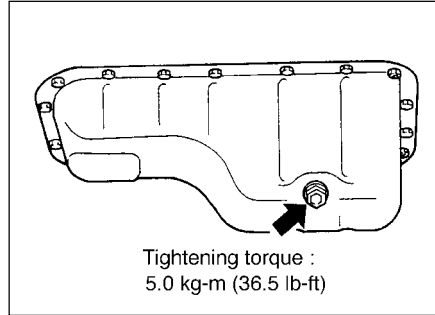

60G-09-004E

### ⚠ WARNING

The engine oil temperature may be high enough to burn your fingers when the drain plug is loosened. Wait until the drain plug is cool enough to touch with your bare hands.

### ⚠ WARNING

New and used oil can be hazardous. Children and pets may be harmed by swallowing new or used oil. Keep new and used oil and used oil filters away from children and pets.

Continuous contact with used engine oil has been found to cause (skin) cancer in laboratory animals. Brief contact with used oil may irritate skin.

To minimize your exposure to used oil, wear a long-sleeve shirt and moistureproof gloves (such as dishwashing gloves) when changing oil. If oil contacts your skin, wash thoroughly with soap and water. Launder any clothing or rags if wet with oil.

Recycle or properly dispose of used oil and filters.

- 4) Reinstall the drain plug and gasket. Tighten the plug to a torque of 5.0 kg-m (36.5 lb-ft).

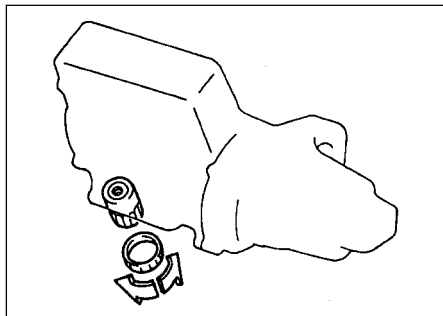

79F-09-004

### Replace the oil filter

- 1) Using an oil filter wrench, turn the oil filter counterclockwise and remove it.
- 2) Using a clean rag, wipe off the mounting surface on the engine where the new filter will be seated.
- 3) Smear a little engine oil around the rubber gasket of the new oil filter.
- 4) Screw on the new filter by hand until the filter gasket contacts the mounting surface.

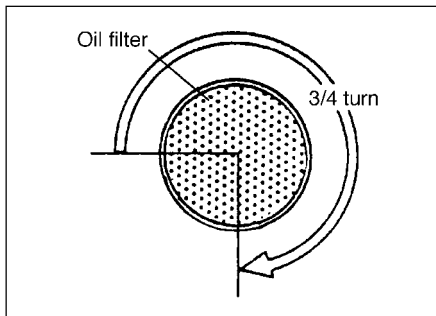

79F-09-005E

### ▲ CAUTION

To tighten the oil filter properly, it is important to accurately identify the position at which the filter gasket first contacts the mounting surface.

- 5) Tighten the filter 3/4 turn from the point of contact with the mounting surface. [or to 1.4 kg-m (10.5 lb-ft)] using an oil filter wrench.

### ▲ CAUTION

To prevent oil leakage, make sure that the oil filter is tight, but do not overtighten it.

### Refill with oil and check for leaks.

- 1) Pour oil through the filler hole and install the filler cap.  
For the approximate capacity of the oil, refer to the "CAPACITIES" item in the "SPECIFICATIONS" section.
- 2) Start the engine and look carefully for leaks at the oil filter and drain plug. Run the engine at various speeds for at least 5 minutes.
- 3) Stop the engine and wait for 5 minutes. Check the oil level again and add oil if necessary. Check for leaks again.

### ▲ CAUTION

When replacing the oil filter, it is recommended that you use a genuine MARUTI replacement filter.

### ▲ CAUTION

Oil leaks from around the oil filter or drain plug indicate incorrect installation or gasket damage. If you find any leaks or are not sure that the filter has been properly tightened, have the vehicle inspected by your MARUTI dealer.

## GEAR OIL

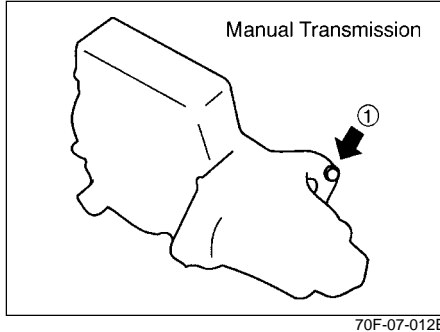

Oil filler and level plug ①  
Tightening torque: 2.1 kg-m (15.5 lb-ft)

**Specified Manual Transmission oil**

When adding gear oil, use the appropriate viscosity and grade as shown in the chart below. We highly recommend you use API GL-4 SAE 75W-90 gear oil.

Type of oil	Gear oil, API GL-4

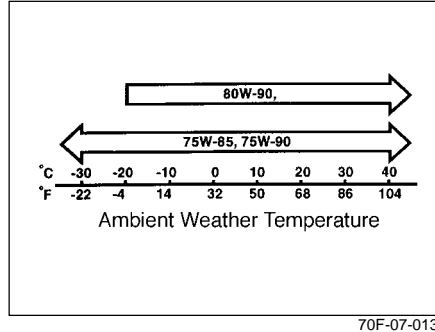
**Gear oil level check**

To check the gear oil level, use the following procedure:

- 1) Park the vehicle on a level surface with the parking brake applied.
- 2) Clean casing around oil filler plug to remove risk of any loose dirt or debris entering oil filler plug hole. Remove the oil filler plug ①.
- 3) Feel the inside of the hole with your finger. If the oil level comes up to the bottom of the plug hole, the oil level is correct. If so, reinstall the plug.
- 4) If the oil level is low, add gear oil through the filler plug hole ① until the oil level reaches the bottom of the filler hole, then reinstall the plug.

**⚠ WARNING**

After driving the vehicle, the transmission oil temperature may be high enough to burn you. Wait until the oil filler plug is cool enough to touch with your bare hands before inspecting transmission oil.

**⚠ CAUTION**

When tightening the plug, apply sealing compound to the plug threads to prevent oil leakage.

**Gear oil change**

Since special procedures, materials and tools are required, it is recommended that you trust this job to your authorized MARUTI dealer.

## AUTOMATIC TRANSMISSION FLUID

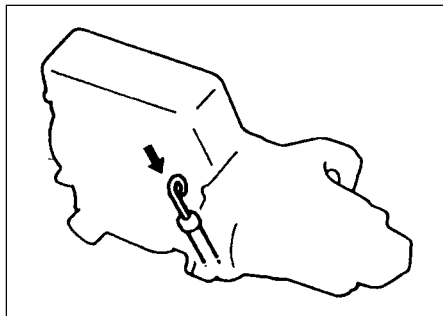

79F-09-006

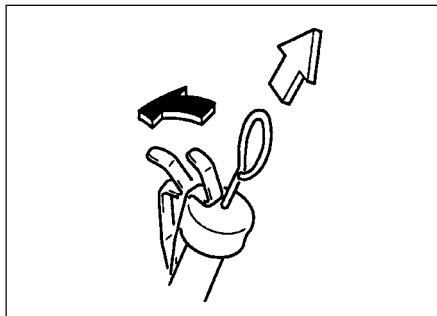

79F-09-007

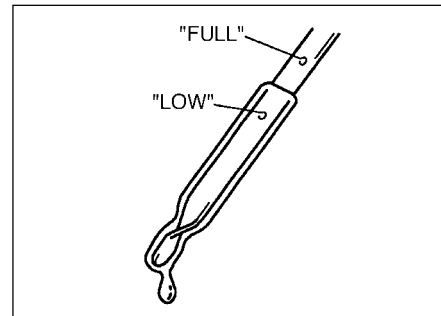

79F-09-008E

**Specified Fluid**

Use an automatic transmission fluid equivalent to DEXRON®-IIE or DEXRON®-III.

**Fluid Level Check****▲ CAUTION**

**Driving with too much or too little fluid can damage the transmission.**

You must check the fluid level with the automatic transmission fluid at normal operating temperature.

To warm up the transmission fluid, drive the vehicle or idle the engine until the temperature gauge indicates normal operating temperature, then drive for ten more minutes.

**9-11**

**NOTE:**

*Do not check the fluid level if you have just driven the vehicle for a long time at high speed, if you have driven in city traffic in hot weather, or if the vehicle has been pulling a trailer. Wait until the fluid cools down (about 30 minutes), or the fluid level indication will not be correct.*

To check the fluid level:

- 1) Park your vehicle on level ground.
- 2) Apply the parking brake and then start the engine in "P" (Park). Let it idle for two minutes and keep it running during the fluid level check.
- 3) With your foot on the brake pedal, move the selector lever through each gear, pausing for about three seconds in each

range. Then move it back to the "P" (Park) position.

**▲ WARNING**

**Be sure to depress the brake pedal when moving the selector lever, or the vehicle can move suddenly.**

- 4) Remove the dipstick, clean it and push it back in until the cap seats, Pull out the dipstick and read the fluid level.

The fluid level should be between the "FULL" and "LOW" marks.

- 5) Add just enough specified fluid through the dipstick hole to fill the transmission to the proper level.

**⚠ CAUTION**

After checking or adding oil, be sure to insert the dipstick securely.

**Changing Oil**

Since special procedures, materials, and tools are required to change the automatic transmission oil, it is recommended that you trust this job to your authorized MARUTI dealer.

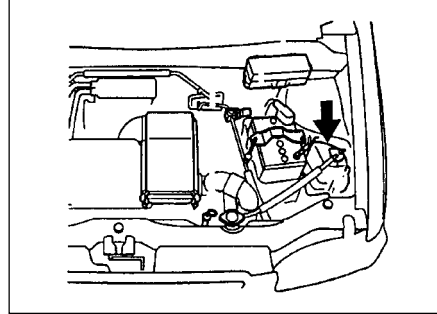
**ENGINE COOLANT**

79F-09-009

**Coolant Level Check**

Check the coolant level at the reservoir tank, not at the radiator. With the engine cool, the coolant level should be between the "FULL" and "LOW" marks.

**Adding Coolant**

If the Coolant level is below the "LOW" mark, more coolant should be added. Remove the reservoir tank cap and add coolant until the reservoir tank level reaches the "FULL" mark. Never fill the reservoir tank above the "FULL" mark.

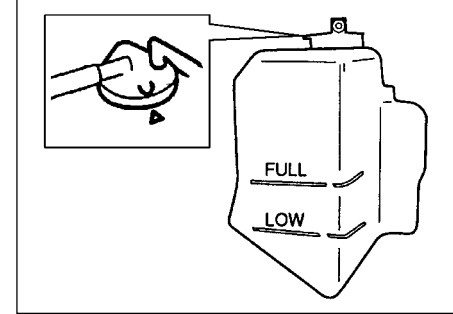

79F-09-010E

**⚠ CAUTION**

- When adding or replacing coolant, use a high quality ethylene glycol antifreeze and anticorrosion (Non-Amine type) diluted with distilled water. If the lowest ambient temperature in your area is expected to be  $-15^{\circ}\text{C}$  ( $5^{\circ}\text{F}$ ) or above, make the antifreeze concentration of the mixture you use at least 30% but no more than 50%. If  $-16^{\circ}\text{C}$  ( $3^{\circ}\text{F}$ ) or below, make the concentration at least 50%. If the 50% concentration does not provide adequate protection against freezing, follow the instructions on the antifreeze



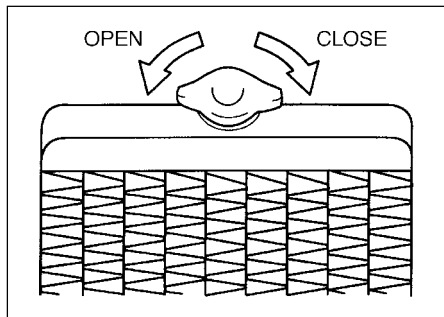

70F-07-019E

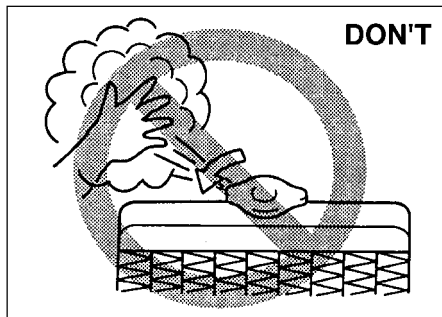

60G-09-039E

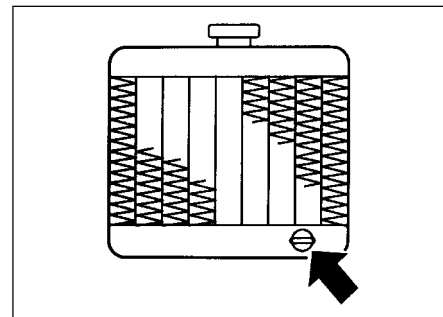

70F-07-017

### ⚠ CAUTION

← container to obtain the desired freezing point.

- When putting the cap on the reservoir tank, line up the arrow on the cap and the arrow on the tank, or coolant can leak out.

### Coolant Replacement

- 1) When the engine is cool, remove the radiator cap by turning it slowly to the left until a "stop" is felt. Do not press down while turning the cap. Wait until any pressure is released, then press down on the cap and continue turning it anticlockwise.

### ⚠ WARNING

It is dangerous to remove the radiator cap when the water temperature is high, because scalding fluid and steam may be blown out under pressure. Wait until the coolant temperature has lowered before removing the cap.

- 2) Remove the reservoir tank cap. Remove the reservoir by lifting it up, and drain the reservoir completely by pouring the coolant in to a suitable container.

- 3) Loosen the drain plug attached to the lower part of the radiator and drain the coolant into a suitable container.
- 4) Tighten the drain plug on the radiator, fill the radiator with coolant and install the radiator cap.
- 5) Refit the reservoir and fill it with the correct coolant to the "FULL" line. Refit the reservoir tank cap, ensuring the arrows are correctly aligned.

### ⚠ CAUTION

The coolant must be replaced with the vehicle on level ground.

## WINDSCREEN WASHER FLUID

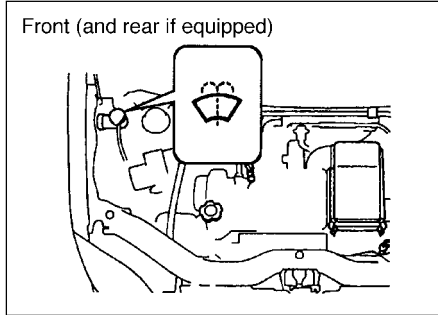

79F-09-011E

Check that there is washer fluid in the tank. Refill it if necessary. Use a good quality windscreen washer fluid, diluted with water as necessary.

**▲ WARNING**

Do not use "antifreeze" solution in the windscreen washer reservoir. This can severely impair visibility when sprayed on the windscreen, and can also damage your vehicle's paint.

**▲ CAUTION**

Damage may result if the washer motor is operated whilst the fluid or fluid nozzles are frozen or with no fluid in the washer tank.

## AIR CLEANER

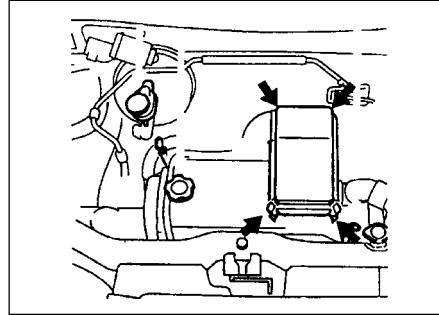

79F-09-012

If the air cleaner is clogged with dust, there will be greater intake resistance, resulting in decreased power output and increased fuel consumption.

Take out the air cleaner element after unhooking the clamps shown in the illustration. Blow off dust on air cleaner element by compressed air. If the air cleaner element appears to be dirty, replace it with a new one.

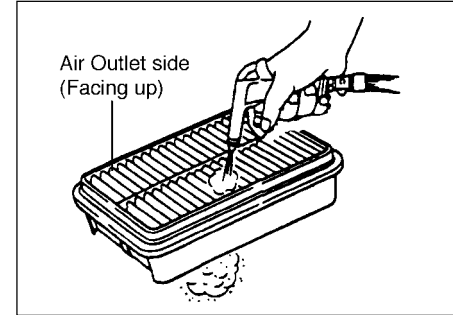

60G-09-010E

**▲ CAUTION**

The air cleaner element should be replaced every 40,000 km. More frequent replacement is necessary when you drive under dusty conditions.

## SPARK PLUGS

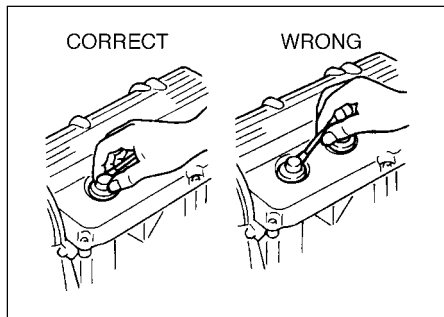

60G-09-011E

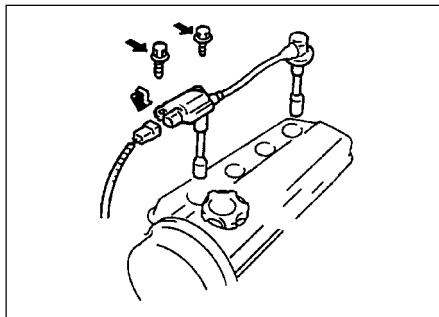

79F-09-013

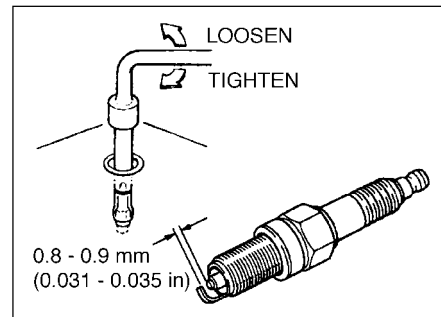

79F-09-014E

You should inspect spark plugs periodically for carbon deposits. When carbon accumulates on a spark plug, a strong spark may not be produced. Remove carbon deposits with a wire or pin and adjust the spark plug gap.

To access the spark plugs,

1. disconnect the coupler while pushing the release lever,
2. remove the bolts, and
3. pull the spark plug boots.

### ▲ CAUTION

- When disconnecting the spark plug cables, pull on the boot, not on the cable itself. Pulling on the cable can damage it.
- When installing the spark plugs, screw them in with your fingers to avoid stripping the threads. Tighten with a torque wrench to 1.3–2.2 kg-m (13.0–22.0 N-m, 9.4–15.9 lb-ft). Do not allow contaminants to enter the engine through the spark plug holes when the plugs are removed.
- Never use spark plugs with the wrong thread size or length.

### ▲ CAUTION

When replacing spark plugs, you should use the brand and type specified for your vehicle. For the specified plugs, refer to the "SPECIFICATIONS" section at the end of this book.

## BRAKES

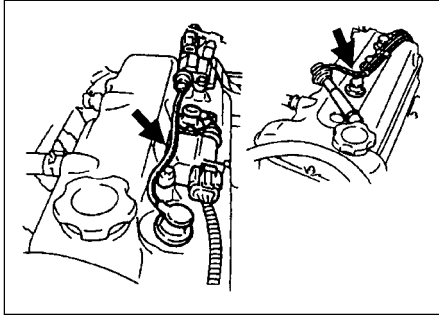

60G-09-013E

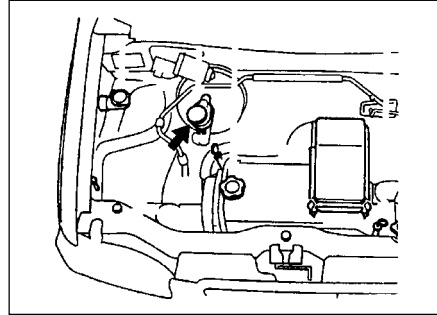

79F-09-015E

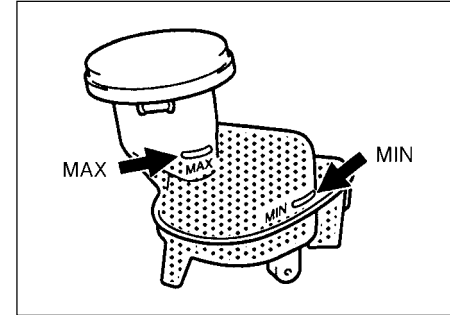

79F-09-016E

**NOTE:**

If you experience some firing problem of spark plugs, such as, hard engine-starting, misfire etc., the cause may be located not only on spark plugs but also on deteriorated ignition wiring (generally, used for more than 80,000 km or five years). If spark plug replacement does not solve the problem, have the ignition wiring and other ignition system inspected by your MARUTI dealer.

**Brake Fluid**

Check the brake fluid level by looking at the reservoir in the engine compartment. Check that the fluid level is between the "MAX" and "MIN" lines. If the brake fluid level is near the "MIN" line, fill it up to the "MAX" line with SAE J1703 or DOT-3 brake fluid.

**▲ WARNING**

Failure to follow the guidelines below can result in personal injury or serious damage to the brake system.

- If the brake fluid in the reservoir drops below a certain level, the brake warning light on the instrument panel will come on (the

**▲ WARNING**

parking brake must be fully disengaged with ignition switch in "ON" position). Should the light come on, immediately ask your MARUTI dealer to inspect the brake system.

- A rapid fluid loss indicates a leak in the brake system which should be inspected by your MARUTI dealer immediately.
- Brake fluid can harm your eyes and damage painted surfaces. Use caution when refilling the reservoir.



70F-07-070

### ▲ WARNING

- Do not use any fluid other than SAE J1703 or DOT-3 brake fluid. Do not use reclaimed fluid or fluid that has been stored in old or open containers. It is essential that foreign particles and other liquids are kept out of the brake fluid reservoir.

### ▲ CAUTION

The brake fluid should be replaced every two years or 20,000 km.

#### NOTE:

With disc brakes, the fluid level can be expected to gradually fall as the brake pads wear.

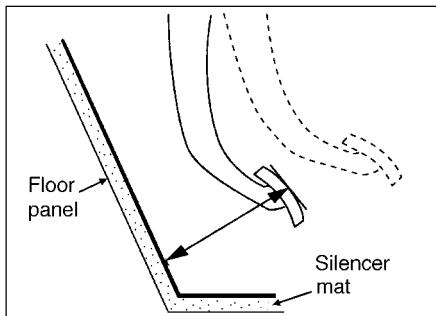

79F-09-017E

#### Brake Pedal

Check if the brake pedal stops at the regular height without "spongy" feeling when you depress it. If not, have the brake system inspected by your MARUTI dealer. If you doubt the brake pedal for the regular height, check it as follows:

With the engine running, measure the distance between the brake pedal and floor silencer mat when the pedal is depressed with approximately 30 kg (66 lbs) of force. The minimum distance required is 125 mm (4.9 in). Since your vehicle's brake system is self-adjusting, there is no need for pedal adjustment. If the pedal to floor wall distance as measured above is less than the minimum distance required, have your vehicle inspected by your MARUTI dealer.

#### NOTE:

When measuring the distance between the brake pedal and floor wall, be sure not to include any floor covering other than silencer mat in the measurement.

### ▲ WARNING

If you experience any of the following problems with your vehicle's brake system, have the vehicle inspected immediately by your MARUTI dealer.

- Poor braking performance
- Uneven braking (Brakes not working uniformly on all wheels.)
- Excessive pedal travel
- Brake dragging
- Excessive noise
- Pedal pulsation (Pedal pulsates when depressed.)

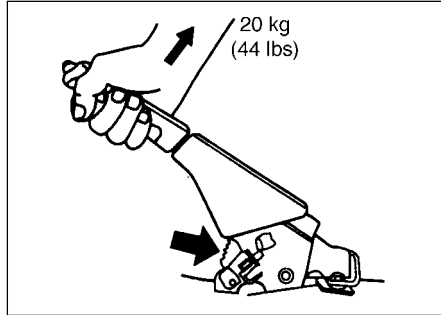

63B-09-005E

### Parking brake

Check the parking brake for proper adjustment by counting the number of clicks made by the ratchet teeth as you slowly pull up on the parking brake lever to the point of full engagement. The parking brake lever should stop between the 7th and 9th ratchet tooth and the rear wheels should be securely locked. If the parking brake is not properly adjusted or the brakes drag after the lever has been fully released, have the parking brake inspected and/or adjusted by your MARUTI dealer.

### STEERING

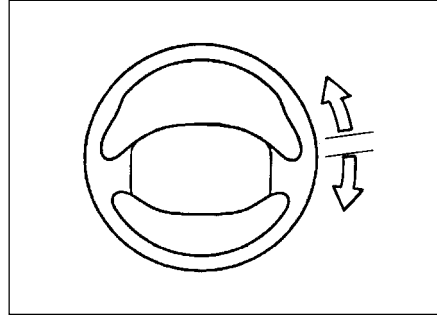

79F-09-018E

Check the play of the steering wheel by gently turning it from left to right and measuring the distance that it moves before you feel slight resistance. The play should be between 0 – 30 mm (0.0 – 1.2 in).

Check that the steering wheel turns easily and smoothly without rattling by turning it all the way to the right and to the left while driving very slowly in an open area. If the amount of free play is outside the specification or you find anything else to be wrong, an inspection must be performed by your MARUTI dealer.

### CLUTCH PEDAL

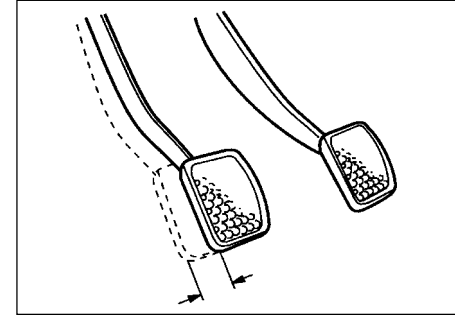

70F-07-034

Measure the clutch pedal play by moving the clutch pedal with your hand and measuring the distance it moves until you feel slight resistance. The play in the clutch pedal should be between 10 – 20 mm (0.4 – 0.8 in). If the play is more or less than the above, or clutch dragging is felt with the pedal fully depressed, have the clutch inspected by your MARUTI dealer.

## TYRES

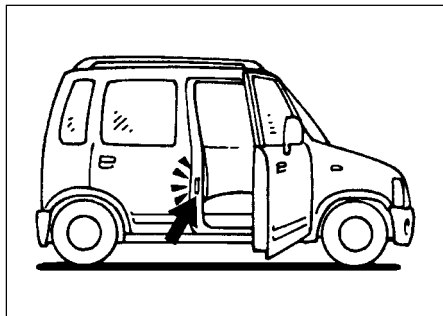

79F-09-019

The front and rear tyre pressure specifications for your vehicle are listed on the Tyre Inflation Pressure Label and in the "SPECIFICATIONS" section at the end of this book. Both the front and rear tyres should have the specified tyre pressure.

**Tyre Inspection**

Inspect your vehicle's tyres periodically by performing the following checks:

- 1) Measure the air pressure with a tyre gauge. Adjust the pressure if necessary.

**▲ WARNING**

- Air pressures should be checked when the tyres are cold or you may get inaccurate readings.
- Check the inflation pressure from time to time while inflating the tyre gradually, until the specified pressure is obtained.
- Never underinflate or overinflate the tyres.

**Underinflation can cause unusual handling characteristics or can cause the rim to slip on the tyre bead, resulting in an accident or damage to the tyre or rim.**

**Overinflation can cause the tyre to burst, resulting in personal injury. Overinflation can also cause unusual handling characteristics which may result in an accident.**

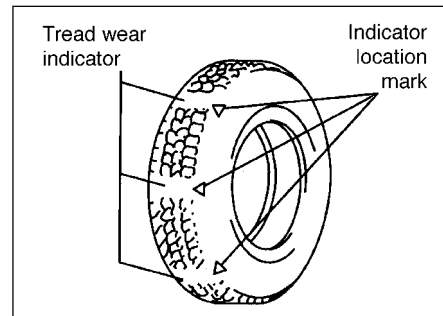

70F-07-037E

- 2) Check that the depth of the tread groove is more than 1.6 mm (0.06 in). To help you check this, the tyres have moulded-in tread wear indicators in the grooves. When the indicators appear on the tread surface, the remaining depth of the tread is 1.6 mm (0.06 in) or less and the tyre should be replaced.
- 3) Check for abnormal wear, cracks and damage. Any tyres with cracks or other damage should be replaced. If any tyres show abnormal wear, have them inspected by your MARUTI dealer.

**⚠ WARNING**

Hitting curbs and running over rocks can damage tyres and affect wheel alignment. Be sure to have tyres and wheel alignment checked periodically by your MARUTI dealer.

- 4) Check for loose wheel nuts.
- 5) Check that there are no nails, stones, or other objects sticking into the tyres.

**⚠ WARNING**

Your MARUTI is equipped with tyres which are all the same type and size. This is important to ensure proper steering and handling of the vehicle. Never mix tyres of different size or type on the four wheels of your vehicle. The size and type of tyres used should be only those approved by MARUTI as standard or optional equipment for your vehicle.

**⚠ WARNING**

Replacing the wheels and tyres equipped on your vehicle with certain combinations of aftermarket wheels and tyres can significantly change the steering and handling characteristics of your vehicle. Therefore, use only those wheel and tyre combinations approved by MARUTI as standard or optional equipment for your vehicle.

**⚠ CAUTION**

Replacing the original tyres with tyres of a different size may result in false speedometer or odometer readings.

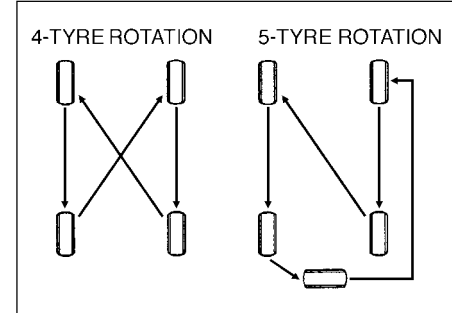

60G-09-019E

**Tyre Rotation**

To avoid uneven wear of your tyres and to prolong their life, rotate the tyres as illustrated. Tyres should be rotated every 5,000 km as recommended in the periodic maintenance schedule. After rotation, adjust front and rear tyre pressures to the specification listed on your vehicle's Tyre Inflation Pressure Label.

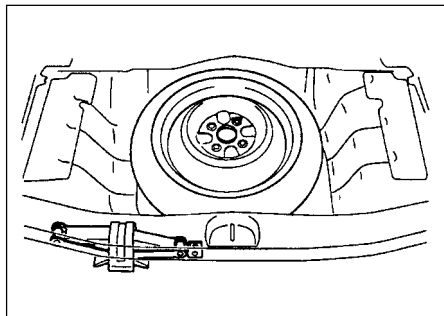

79F-06-021

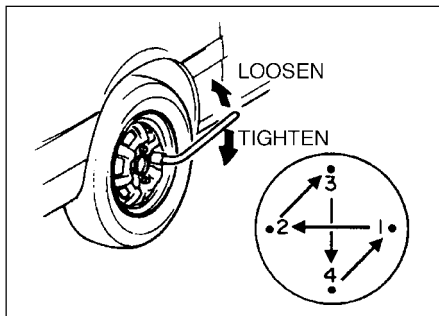

79F-09-020E

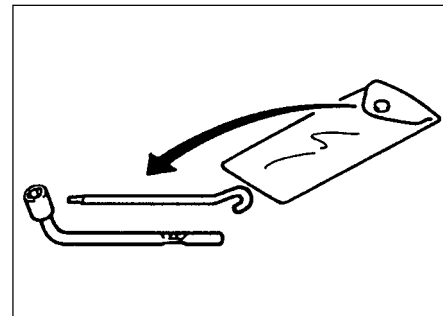

79F-06-022

### Changing Wheels

To change a wheel, use the following procedure:

- 1) Remove the jack, tools and spare wheel from the vehicle

#### NOTE:

*If it is hard to loosen the wing bolt that secures the spare tyre, use the jack crank as illustrated.*

- 2) Loosen, but do not remove the wheel nuts.
- 3) Jack up the vehicle (follow the jacking instructions in the EMERGENCY SERVICE section in this manual)

- 4) Remove the wheel nuts and wheel.
- 5) Install the new wheel and replace the wheel nuts with their cone shaped end facing the wheel. Tighten each nut snugly by hand until the wheel is securely seated on the hub.
- 6) Lower the jack and fully tighten the nuts [to 8.5 kg-m (61.5 lb-ft)] in a crisscross fashion with a wrench as shown in the illustration.

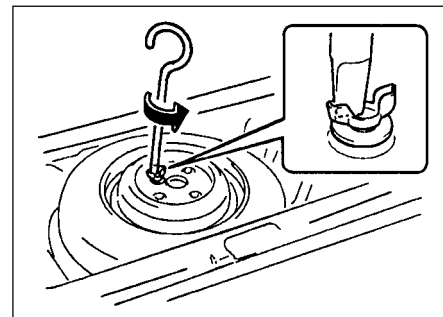

79F-06-023

## BATTERY

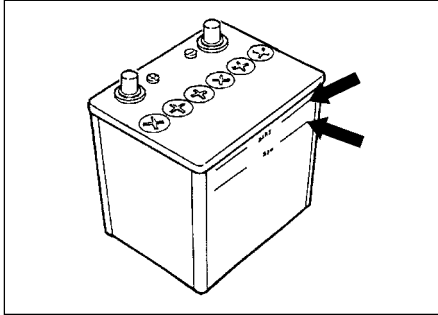

60G-09-038

**⚠ WARNING**

Batteries produce flammable hydrogen gas. Keep flames and sparks away from the battery or an explosion may occur. Never smoke when working in the vicinity of the battery .

**⚠ WARNING**

When checking or servicing the battery, disconnect the negative cable. Be careful not to cause a short circuit by allowing metal objects to contact the battery posts and the vehicle at the same time.

**⚠ WARNING**

To avoid harm to yourself or damage to your vehicle or battery, follow the jump starting instructions in the EMERGENCY SERVICE section of this manual if it is necessary to jump start your vehicle.

The level of the battery solution must be kept between the "UPPER" and the "LOWER" level lines at all times. If the level is found to be below the "LOWER" level line, add distilled water to the "UPPER" level line. You should periodically check the battery, battery terminals, and battery hold-down bracket for corrosion. Remove corrosion using a stiff brush and ammonia mixed with water, or baking soda mixed with water. After removing corrosion, rinse with clean water.

If your vehicle is not going to be driven for a month or longer, disconnect the cable from the negative terminal of the battery to help prevent discharge.

## FUSES

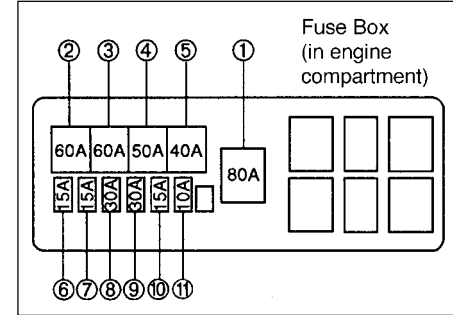

79F-09-021E

- ①. Main fuse
- ②. Primary fuse (IG)
- ③. Primary fuse (Not under ignition switch)
- ④. Empty
- ⑤. Empty
- ⑥. Headlight (R)
- ⑦. Headlight (L)
- ⑧. Heater fuse
- ⑨. Radiator fan motor fuse
- ⑩. Fuel injection system fuse
- ⑪. Air conditioner

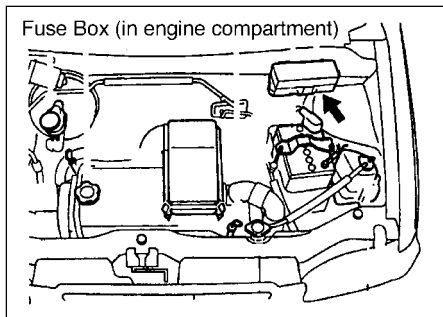

79F-09-022E

This vehicle has three types of fuses, as described below :

**Main Fuse** - The main fuse takes current directly from the battery.

**Primary Fuses** - These fuses are between the main fuse and individual fuses, and are for electrical load groups.

**Individual Fuses** - These fuses are in the fuse box and for individual electrical circuits.

MAIN FUSE / PRIMARY FUSES	
80A	All Electric Load
60A (IG)	CIGAR, TURN/BACK, I.G./METER, HEATER, REAR DEF/W, WIPER/WASHER, POWER WINDOW
60A	DOOR LOCK, TAIL, STOP, RADIO/DOME, HORN/HAZARD

**Main Fuse and Primary Fuses**

The main fuse and primary fuses are located in the engine compartment. If the main fuse blows, no electrical component will function. If a primary fuse blows, no electrical component in the corresponding load group will function. When replacing the main fuse or a primary fuse, use a genuine MARUTI replacement.

**▲ WARNING**

**If the main fuse or a primary fuse blows, be sure to have your vehicle inspected by an authorized MARUTI dealer. Always use a genuine MARUTI replacement. Never use a substitute such as a wire even for a temporary repair, or extensive electrical damage and a fire can result.**

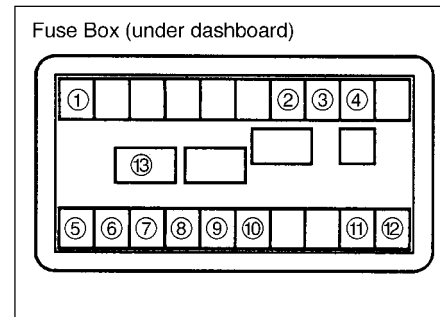

79F-09-023E

- ①. CIGAR 15A
- ②. WIPER/WASHER 15A
- ③. TURN/BACK 10A
- ④. IG/METER 15A
- ⑤. -----
- ⑥. HORN HAZARD 15A
- ⑦. RADIO/DOME 15A
- ⑧. TAIL 10A
- ⑨. STOP 10A
- ⑩. DOOR LOCK 20A
- ⑪. -----
- ⑫. HEATER 10A
- ⑬. POWER WINDOW 30A

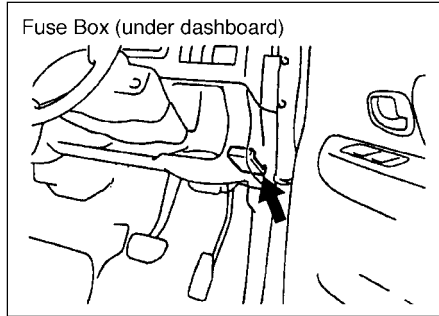

79F-09-024E

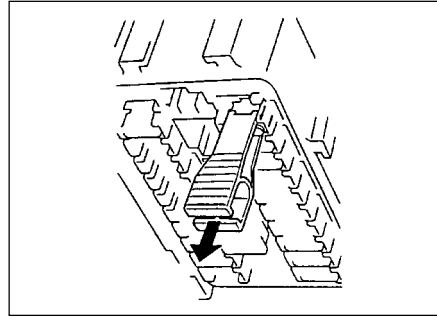

79F-09-025

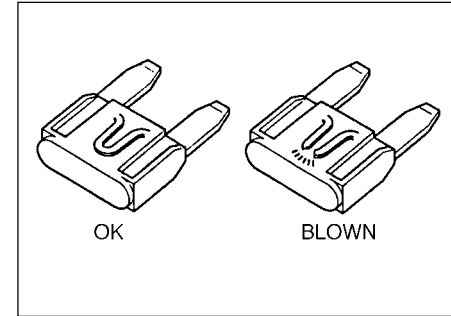

79F-09-026

### Fuse Box

The fuse boxes are located in the engine compartment and under the driver's side of the dashboard.

To remove the fuse box cover under the dashboard pull off the cover.

#### NOTE:

To remove the fuse from the fuse box use the fork given in the fuse box (under dashboard) as shown in the illustration.

**⚠ WARNING**

Always be sure to replace a blown fuse with a fuse of the correct amperage. Never use a substitute such as aluminium foil or wire to replace a blown fuse. If you replace a fuse and the new one blows in a short period of time, you may have a major electrical problem. Have your vehicle inspected immediately by your MARUTI dealer.

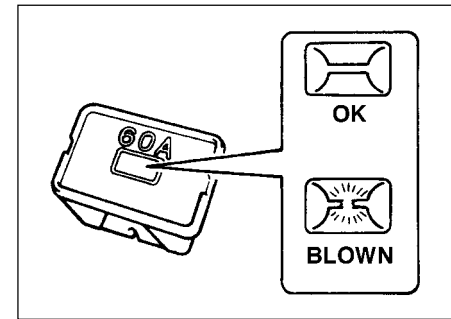

60G-09-028E

#### NOTE:

Make sure that the fuse box always carries spare fuses.

## BULB REPLACEMENT

**⚠ WARNING**

- Light bulbs can be hot enough to burn your finger right after being turned off. This is true especially for halogen headlight bulbs. Replace the bulbs after they become cool enough.
- The headlight bulbs are filled with pressurized halogen gas. They can burst and injure you if they are hit or dropped. Handle them carefully.

**⚠ CAUTION**

The oils from your skin may cause a halogen bulb to overheat and burst when the lights are on. Grasp a new bulb with a clean cloth.

**⚠ CAUTION**

Frequent replacement of a bulb indicates the need for an inspection of the electrical system. This should be carried out by your MARUTI dealer.

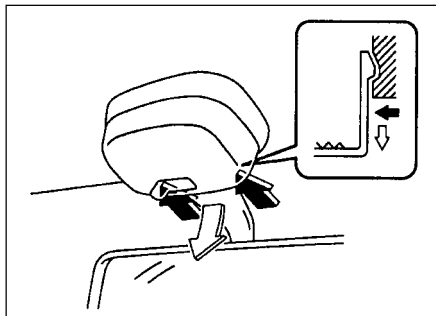

79F-09-027

**Front Interior Light**

Press the front part of the lens toward you and pull down the lens. To install it, simply push it back in.

The bulb can be removed by simply pulling it out. When replacing the bulb, make sure that the contact springs are holding the bulb securely.

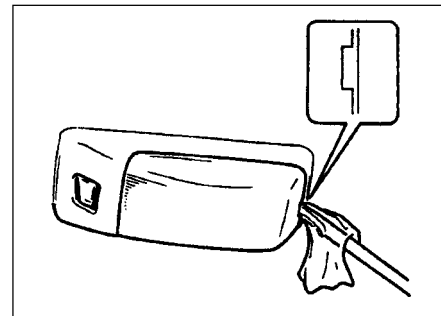

79F-09-028

**Rear Interior Light (if equipped)**

Pull down the lens by using a plain screw driver covered with a soft cloth as shown. To install it, simply push it back in.

The bulb can be removed by simply pulling it out.

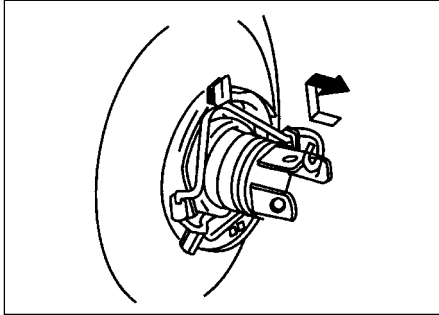

70F-07-049

### Headlights

Open the bonnet. Disconnect the coupler. Remove the sealing rubber.

Push the retaining spring forward and unhook it. Then remove the bulb. Install a new bulb in the reverse order of removal.

#### Note:

*Your vehicle is provided with two spare headlight bulbs for replacement in emergency.*

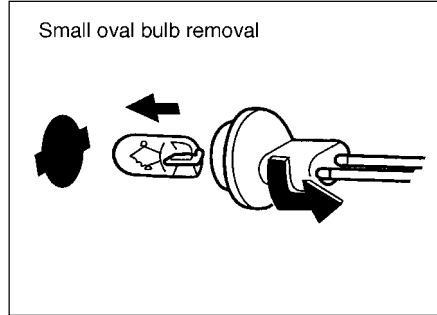

70F-07-050E

### Front Clearance/Turn Signal Light, Side Turn Signal Light, rear Combination Light, Registration Plate Light.

To remove a bulb holder from a light housing, turn the holder counterclockwise and pull it out. To install the holder, push the holder in and turn it clockwise.

Two types (small oval and round) of bulb are used for these lights. To remove and install a small oval bulb, simply pull out or push in the bulb.

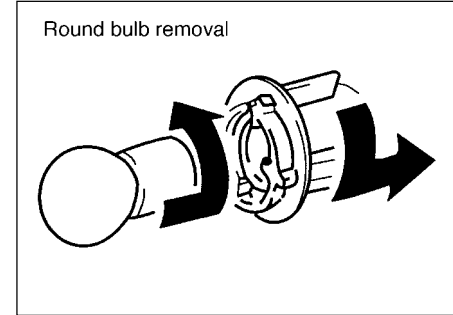

70F-07-051E

To remove a round bulb from a bulb holder, push in the bulb and turn it counterclockwise. To install a new bulb, push it in and turn it clockwise. You can access the individual bulb holders as described below:

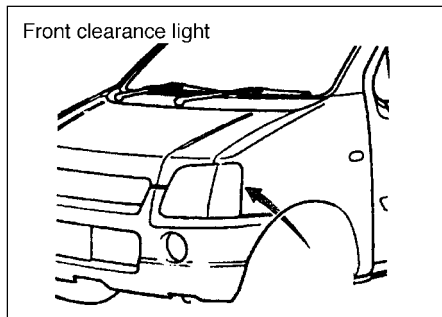
**Front clearance light**

Trust this replacement job to your authorized MARUTI dealer as the front part of the front fender liner must be detached to replace the bulb.

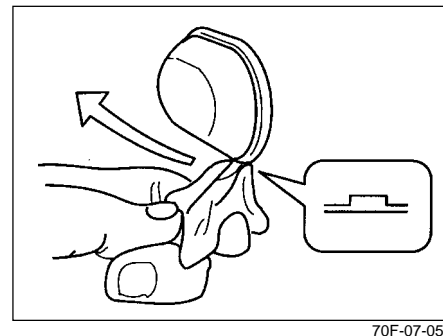
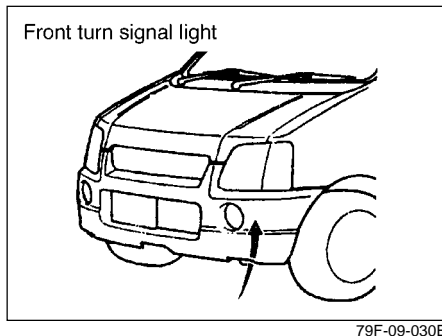
**Side turn signal light**

Remove the lens by using a plain screw driver covered with a soft cloth.

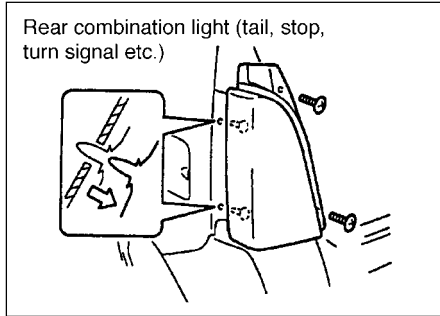

### Rear combination light (tail, stop, turn signal, etc.)

Undo the screws that secure the housing and remove the housing by sliding in the direction of the white arrow in the illustration.

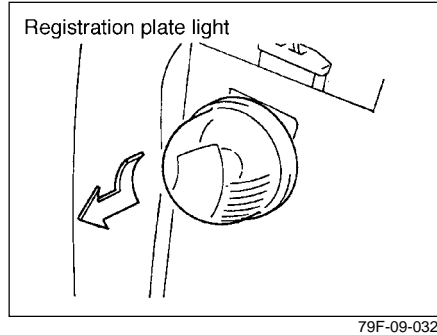

### Registration plate light

Turn the lens counterclockwise and pull it off

## WIPER BLADES

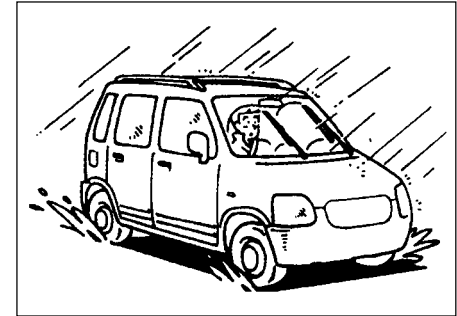

If the wiper blades become brittle or damaged, or make streaks when wiping, replace the wiper blades.

To install new wiper blades, follow the procedure below.

### ▲ CAUTION

To avoid scratching or breaking the window, do not let the wiper arm strike the windshield while replacing the wiper blade.

**NOTE:**

Some wiper blades may be different from the ones described here depending on vehicle specifications. If so consult your MARUTI dealer for proper replacement method.

**▲ WARNING**

The left and the right wiper arm assemblies are different from each other. In case you have to remove the wiper arm assemblies for any reason, remember not to interchange the two while fitting them back. Wrong fitment may lead to windshield breakage.

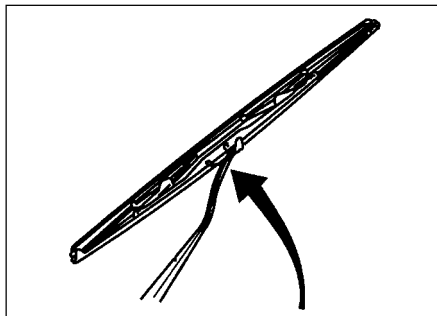

70F-07-060

**For windshield wipers:**

1. Hold the wiper arm away from the window.

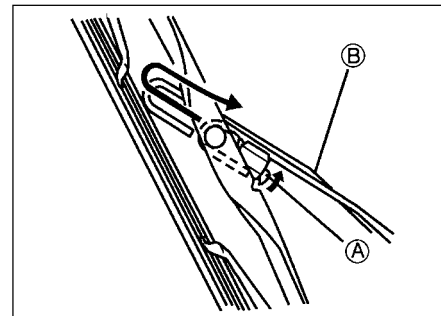

72F-09-008

2. Squeeze lock lever (A) towards wiper arms (B) and remove the wiper frame from the arm as shown.

## EMERGENCY SERVICE

Jacking Instructions.....	10-1
Jump Starting Instructions.....	10-2
Towing .....	10-4
Emergency Remedies .....	10-4
Warning Triangle .....	10-5

## JACKING INSTRUCTIONS

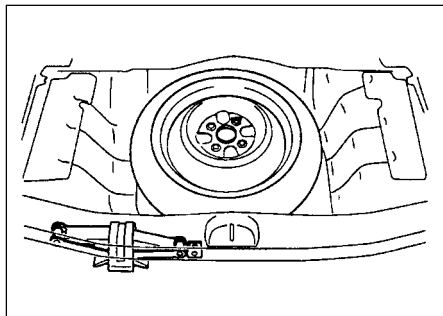

79F-06-023

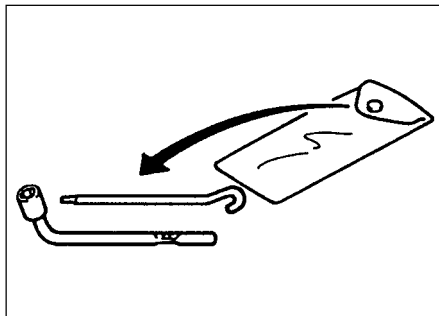

79F-06-024

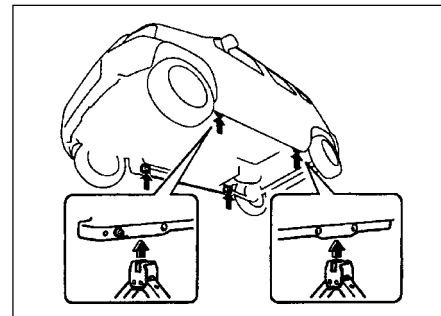

79F-10-001

- 1) Park the vehicle securely on hard level ground.
- 2) Apply the parking brake firmly and select "P" (Park) if your vehicle has an automatic transmission, or change into "R" (Reverse) if your vehicle has a manual transmission. Choke the front and rear wheel diagonally opposite the wheel to be changed.
- 3) Switch on the hazard warning flasher if your vehicle is in or near traffic.
- 4) Slacken but do not remove wheel nuts on the wheel to be changed.
- 5) Position the jack vertically and raise the jack by turning the jack handle clockwise until the jack head recess fits the frame boss.

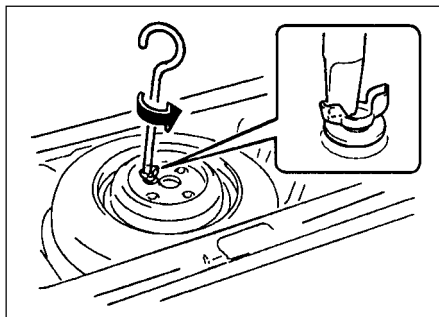

79F-06-025

- 6) Continue to raise the jack slowly and smoothly until the tyre clears the ground. Do not raise the vehicle more than necessary.

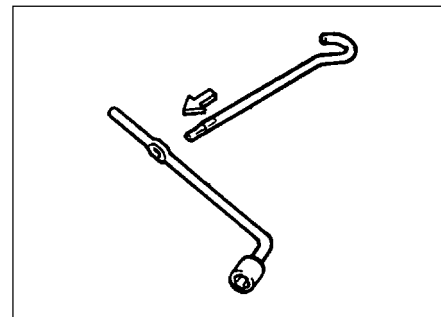

60G-10-001

**NOTE:**  
Use the wheel nut wrench in combination with jack crank to raise or lower the jack as shown in the illustration.

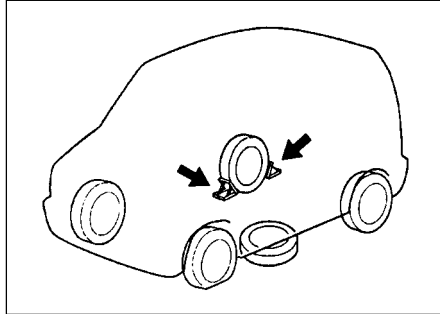

79F-10-002

### ⚠ WARNING

- Use the jack only to change wheels.
- Never jack up the vehicle on an inclined surface.
- Never raise the vehicle with the jack in a location other than under the frame boss near the wheel to be changed.
- Make sure that the jack is raised at least 2 inches (51 mm) before it contacts the vehicle. Use of the jack when it is within 2 inches of being fully collapsed may result in failure of the jack.
- Never get under the vehicle when it is supported by the jack.
- Never run the engine when the vehicle is supported by the jack and

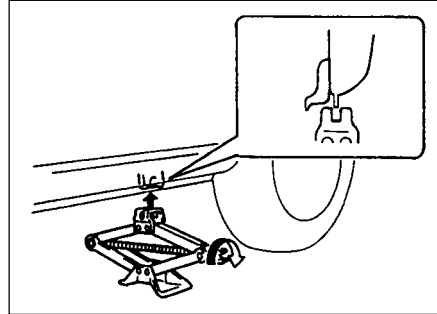

79F-10-003

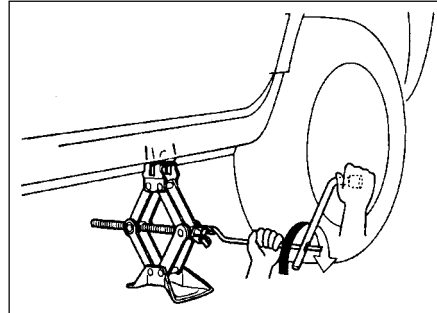

79F-10-004

### ⚠ WARNING

← never allow passengers to remain in the vehicle. →

## JUMP STARTING INSTRUCTIONS

### ⚠ WARNING

- Never attempt to jump start your vehicle if the battery appears to be frozen. Batteries in this condition may explode or rupture if jump starting is attempted.
- When making jump lead connections, be certain that your hands and the jump leads remain clear from pulleys, belts, or fans.
- Batteries produce flammable hydrogen gas. Keep flames and sparks away from the battery or an explosion may occur. Never smoke when working in the vicinity of the battery.
- If the booster battery you use for jump starting is installed in another vehicle, make sure the two vehicles are not touching each other.
- If your battery discharges repeatedly, for no apparent reason, have your vehicle inspected by an authorized MARUTI dealer.
- To avoid harm to yourself or damage to your vehicle or battery, follow the jump starting instructions below precisely and in order. If you are in doubt, call for qualified road service.

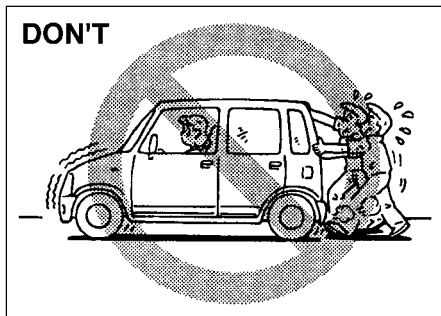

79F-10-005E

**⚠ CAUTION**

- Vehicle equipped with electronic fuel injection system will not start by pushing or towing as the fuel pump will not work in this condition. This starting method could also result in permanent damage to the catalytic converter. Use jump leads to start a vehicle with a weak or flat battery.

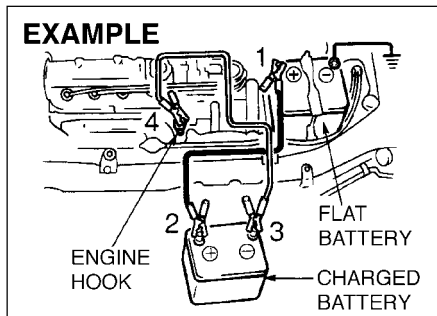

79F-10-006E

When jump starting your vehicle, use the following procedure:

- 1) Use only a 12 volt battery to jump start your vehicle. Position the good 12V battery close to your vehicle so that the jump leads will reach both batteries. When using a battery installed on another vehicle, DO NOT LET THE VEHICLES TOUCH. Apply the parking brakes fully on both vehicles.
- 2) Turn off all vehicle accessories, except those necessary for safety reasons (for example, headlights or hazard lights).

3) Make jump lead connections as follows:

- a) Connect one end of the first jump lead to the positive (+) terminal of the flat battery.
- b) Connect the other end to the positive (+) terminal of the booster battery.
- c) Connect one end of the second jump lead to the negative (-) terminal of the booster battery.
- d) Make the final connection to an unpainted, heavy metal part of the engine of the vehicle with the flat battery.

**⚠ WARNING**

**Never connect the jump lead directly to the negative (-) terminal of the discharged battery, or an explosion may occur.**

- 4) If the booster battery you are using is fitted to another vehicle, start the engine of the vehicle with the booster battery. Run the engine at moderate speed.
- 5) Start the engine of the vehicle with the flat battery.
- 6) Remove the jump leads in the exact reverse order in which you connected them.

## TOWING



79F-10-007

If you need to have your vehicle towed, contact a professional service. Your dealer can provide you with detailed towing instructions

**▲ CAUTION**

To help avoid damage to your vehicle during towing, proper equipment and towing procedures must be used.

**Manual Transmission**

Whenever possible, your vehicle should be towed from the front with the front wheels lifted. If the steering and drivetrain are in good condition, your vehicle may be towed from the rear with the rear wheels lifted and the front wheels on the ground. Before towing, make sure the steering is unlocked and the transmission is in neutral.

**Automatic Transmission**

Your vehicle may be towed from the front with the front wheels lifted, or from the rear with the rear wheels lifted and a dolly under the front wheels. Before towing, make sure that the parking brake is released.

**▲ CAUTION**

Towing your vehicle with the front wheels on the ground can result in damage to the automatic transmission.

## EMERGENCY REMEDIES

**If the Starter Does Not Operate:**

- 1) Try turning the ignition switch to the "START" position with the headlights turned on to determine the battery condition. If the headlights go excessively dim or go off, it usually means that either the battery is flat or the battery terminal contact is poor. Recharge the battery or correct battery terminal contact as necessary.
- 2) If the headlights remain bright, check the fuses. If the reason for failure of the starter is not obvious, there may be a major electrical problem. Have the vehicle inspected by your authorized MARUTI dealer.

**If the Engine is Flooded**

If the engine is flooded with petrol, it may be hard to start. If this happens, press the accelerator pedal all the way to the floor and hold it there while cranking the engine. (Do not operate the starter motor for more than 15 seconds). Release the accelerator as soon as the engine has started.

**If the Engine Overheats**

The engine could overheat temporarily under severe driving conditions. If the engine coolant temperature gauge indicates overheating during driving:

- 1) Turn off the air conditioner, if equipped.
- 2) Take the vehicle to a safe place and park.
- 3) Let the engine run at normal idle speed for a few minutes until the indicator is within the normal, acceptable temperature range between "H" and "C".

### **▲ WARNING**

**If you see or hear escaping steam, stop the vehicle in a safe place and immediately turn off the engine to let it cool. Do not open the bonnet when steam is present. When the steam can no longer be seen or heard, open the hood to see if the coolant is still boiling. If it is, you must wait until it stops boiling before you proceed.**

If the temperature indication does not come down to within the normal, acceptable range:

- 1) Turn off the engine and check that the water pump belt and pulleys are not damaged or slipping. If any abnormality is found, correct it.
- 2) Check the coolant level in the reservoir. If it is found to be lower than the "LOW" line, look for leaks at the radiator, water pump, and radiator and heater hoses. If

you locate any leaks that may have caused the overheating, do not run the engine until these problems have been corrected.

- 3) If you do not find a leak, carefully add coolant to the reservoir and then the radiator, if necessary. (Refer to "ENGINE COOLANT" in the "INSPECTION AND MAINTENANCE" section.)

### **▲ WARNING**

**It is dangerous to remove the radiator cap when the water temperature is high, because scalding fluid and steam may be blown out under pressure. The cap should only be taken off when the coolant temperature has lowered.**

### **▲ WARNING**

**To help prevent personal injury, keep hands, tools and clothing away from the engine cooling fan and air-conditioner fan (if equipped). These electric fans can automatically turn on without warning.**

## WARNING TRIANGLE

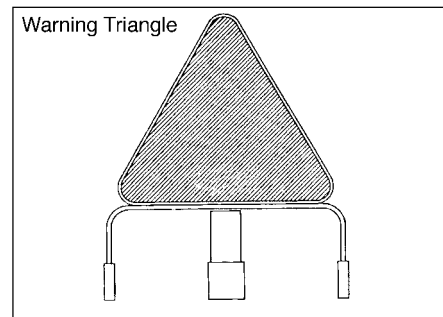

843-10-004

In case of vehicle break-down or during emergency stopping where your vehicle could become a potential traffic hazard, please keep the warning triangle, provided with your vehicle, on the pathway (road) behind the vehicle so as to warn the approaching traffic, at an approximate distance of 5-15 m, such that reflecting side of the triangle faces the rear. Please activate the hazard warning lamps before alighting the vehicle to keep the warning triangle.

## **BODY WORK CARE**

<b>Corrosion Prevention .....</b>	<b>11-1</b>
<b>Vehicle Cleaning .....</b>	<b>11-2</b>

## **CORROSION PREVENTION**

It is important to take good care of your vehicle to protect it from corrosion.

Listed below are instructions for how to maintain your vehicle to prevent corrosion. Please read and follow these instructions carefully.

### **Important Information About Corrosion**

#### **Common causes of corrosion**

- 1) Accumulation of road salt, dirt, moisture, or chemicals in hard to reach areas of the vehicle underbody or frame.
- 2) Chipping, scratches and any damage to treated or painted metal surfaces resulting from minor accidents or abrasion by stones and gravel.

#### **Environmental conditions which accelerate corrosion**

- 1) Road salt, dust control chemicals, sea air or industrial pollution will all accelerate the corrosion of metal.
- 2) High humidity will increase the rate of corrosion particularly when the temperature range is just above the freezing point.
- 3) Moisture in certain areas of a vehicle for an extended period of time may promote corrosion even though other body sections may be completely dry.
- 4) High temperatures will cause an

accelerated rate of corrosion to parts of the vehicle which are not well ventilated to permit quick drying.

This information illustrates the necessity of keeping your vehicle (particularly the underbody) as clean and dry as possible. It is equally important to repair any damage to the paint or protective coatings as soon as possible.

#### **How to Help Prevent Corrosion**

##### **Wash your vehicle frequently**

The best way to preserve the finish on your vehicle and to help avoid corrosion is to keep it clean with frequent washing.

Wash your vehicle regularly during the winter and immediately after the winter. Keep your vehicle, particularly the underside, as clean and dry as possible.

If you frequently drive on salted roads, your vehicle should be washed at least once a month during the winter. If you live near the ocean, your vehicle should be washed at least once a month throughout the year. For washing instructions, refer to the "VEHICLE CLEANING" section.

##### **Remove foreign material deposits**

Foreign material such as salts, chemicals, road oil or tar, tree sap, bird droppings and industrial fall-out may damage the finish of your vehicle if it is left on painted surfaces.

Remove these types of deposits as quickly as possible. If these deposits are difficult to wash off, an additional cleaner may be required. Be sure that any cleaner you use is not harmful to painted surfaces and is specifically intended for your purposes. Follow the manufacturer's directions when using these special cleaners.

##### **Repair finish damage**

Carefully examine your vehicle for damage to the painted surfaces. Should you find any chips or scratches in the paint, touch them up immediately to prevent corrosion from starting. If the chips or scratches have gone through to the bare metal, have a qualified body shop make the repair.

##### **Keep Passenger and luggage compartments clean.**

Moisture, dirt or mud can accumulate under the floor mats and may cause corrosion. Occasionally, check under these mats to ensure that this area is clean and dry. More frequent checks are necessary if the vehicle is used off road or in wet weather.

Certain cargos such as chemicals, fertilizers, cleaners, salts, etc., are extremely corrosive by nature. These products should be transported in sealed containers. If a spill or leak does occur, clean and dry the area immediately.

## VEHICLE CLEANING

### Store your vehicle in a dry, well-ventilated area.

Do not park your vehicle in a damp, poorly ventilated area. If you often wash your vehicle in the garage or if you frequently drive it in when wet, your garage may be damp. The high humidity in the garage may cause or accelerate corrosion. A wet vehicle may corrode even in a heated garage if the ventilation is poor.

#### **⚠ WARNING**

**Do not apply additional undercoating or rust preventive coating on or around exhaust system components such as the exhaust pipes, etc. A fire could be started if the undercoating substance becomes overheated.**

### Cover your vehicle

If you cannot regularly park your vehicle in a garage, we recommend you use a vehicle cover. Years of exposure to midday sun can cause the colours in paint, plastic parts, and fabrics to fade. Covering your vehicle with a high-quality, "breathable" vehicle cover can help protect the finish from the harmful UV rays in sunlight, and can reduce the amount of dust and air pollution reaching the surface.

#### **⚠ WARNING**

**When cleaning the interior or exterior of the vehicle, NEVER USE flammable solvents such as lacquer thinners, petrol, benzene or cleaning materials such as bleach or strong household detergents. The materials could cause personal injury or damage to the vehicle.**

### Cleaning the Interior

#### Vinyl upholstery

Prepare a solution of soap or mild detergent mixed with warm water. Apply the solution to the vinyl with a sponge or soft cloth and let it soak for a few minutes to loosen dirt. Rub the surface with a clean, damp cloth to remove dirt and the soap solution. If some dirt still remains on the surface, repeat this procedure.

#### Fabric upholstery

Remove loose dirt with a vacuum cleaner. Using a mild soap solution, rub stained areas with a clean damp cloth. To remove soap, rub the areas again with a cloth dampened with water. Repeat this until the stain is removed, or use a commercial fabric

cleaner for tougher stains. If you use a fabric cleaner, carefully follow the manufacturer's instructions and precautions.

#### Seat Belts

Clean seat belts with a mild soap and water. Do not use bleach or dye on the belts. They may weaken the fabric in the belts.

#### Vinyl floor mats

Ordinary dirt can be removed from vinyl with water or mild soap. Use a brush to help loosen dirt. After the dirt is loosened, rinse the mat thoroughly with water and dry it in the shade.

#### Carpets

Remove dirt and soil as much as possible with a vacuum cleaner. Using a mild soap solution, rub stained areas with a clean damp cloth. To remove soap, rub the areas again with a cloth dampened with water. Repeat this until the stain is removed, or use a commercial carpet cleaner for tougher stains. If you use a carpet cleaner, carefully follow the manufacturer's instructions and precautions.

**Cleaning the Exterior**

<b>▲ CAUTION</b>
It is important that your vehicle be kept clean and free from dirt. Failure to keep your vehicle clean may result in fading of the paint or corrosion to various parts of the vehicle body.

**Washing**

<b>▲ WARNING</b>
<ul style="list-style-type: none"> <li>• Never attempt to wash and wax your vehicle with the engine running.</li> <li>• When cleaning the underside of the body and fender, where there may be sharp-edged parts, you should wear gloves and a longsleeved shirt to protect your hands and arms from being cut.</li> <li>• After washing your vehicle, carefully test the brakes before driving to make sure they have maintained their normal effectiveness.</li> </ul>

When washing the vehicle, follow the instructions below:

- 1) Flush the underside of body and wheel housings with pressurized water to remove mud and debris. Use plenty of water.

<b>▲ CAUTION</b>
When washing the vehicle, avoid directing steam or hot water of more than 80°C (176°F) on plastic parts.

- 2) Remove dirt and mud from the body exterior with running water. You may use a soft sponge or brush. Do not use hard materials which can scratch the paint.
- 3) Wash the entire exterior with a mild detergent or car wash soap using a sponge or soft cloth. The sponge or cloth should be frequently soaked in the soap solution.

<b>▲ CAUTION</b>
When using a commercial car wash product, observe the cautions specified by the manufacturer. Never use strong household detergents or soaps.

- 4) Once the dirt has been completely removed, rinse off the detergent with running water.
- 5) After rinsing, wipe off the vehicle body with a wet chamois or cloth and allow it to dry in the shade.
- 6) Check carefully for damage to painted surfaces. If there is any damage, "Touchup" the damage following the procedure below:
  - a) Clean all damaged spots and allow them to dry.
  - b) Stir the paint and "touchup" the damaged spots lightly using a small brush.
  - c) Allow the paint to dry completely.

**Waxing**

After washing the vehicle, waxing and polishing are recommended to further protect and beautify the paint.

- Only use waxes and polishes of good quality.
- When using waxes and polishes, observe the precautions specified by the manufacturers.

## GENERAL INFORMATION

Vehicle Identification ..... 12-1

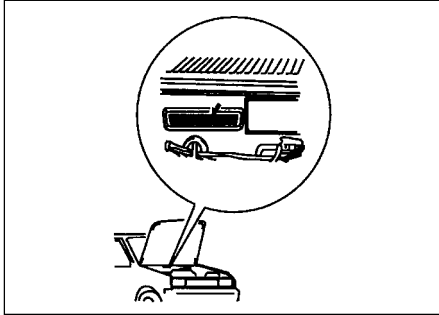
**VEHICLE IDENTIFICATION**

70F-10-001

**Chassis Serial Number**

The chassis and/or engine serial numbers are used to register the vehicle. They are also used to assist your dealer when ordering or referring to special service information. Whenever you have occasion to consult your MARUTI dealer, remember to identify your vehicle with this number. Should you find the number difficult to read, you will also find it on the identification plate.

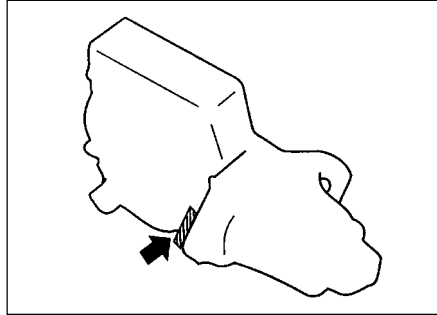

70F-10-002

**Engine Serial Number**

The engine serial number is stamped on the cylinder block as shown in the illustration and also on the identification plate.



## SPECIFICATIONS

79F-74E

<p><b>ELECTRICAL</b>  Standard spark plug  Battery  Fuses  Headlight  Turn signal light  Side turn signal light  Clearance light  Tail/brake light  Registration plate light  Reversing light</p>	<p>NGK – DCPR7E  38B20L (28AH/5HR)  See “INSPECTION AND MAINTENANCE” section  12V 60/55W  12V 21W  12V 5W  12V 5W  12V 5/21W  12V 5W  12V 18W</p>
<p><b>WHEEL AND SUSPENSION</b>  Tyre size, front and rear  Tyre pressures front/rear  Suspension type           front    rear</p>	<p>145/70R13  2.3 kg/cm<sup>2</sup>  strut  coil spring</p>
<p><b>STEERING</b>  Toe-in                           front</p>	<p>0±2 mm</p>
<p><b>CAPACITIES</b>  Coolant  (Including reservoir tank)  Fuel tank  Engine oil  Transmission oil</p>	<p>4.0 L  35 L  3.7 L (Replacement with Oil Filter)  M/T.....2.1 L  A/T.....4.1 L (Total quantity)</p>